

Battery-Box Premium Operating Manual



HVS 5.1, 7.7, 10.2, 12.8

HVM 8.3, 11.0, 13.8, 16.6, 19.3, 22.1

A High-Voltage Battery System

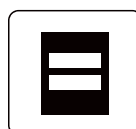

Legal Provisions

All the information in this document is the property of Shenzhen BYD Electronics Co., Ltd. No part of this document could be reproduced in any way for business use. Internal use is allowed.

Shenzhen BYD Electronics Co., Ltd. makes no representations or warranties express or implied, with respect to this document or any of the equipment and/or software it may describe, including (with no limitation) any implied warranties of utility, merchantability, or fitness for any particular purpose. All such representations or warranties are expressly disclaimed. Neither Shenzhen BYD Electronics Co., Ltd. nor its distributors or dealers shall be liable for any indirect, incidental, or consequential damages under any circumstances.

The exclusion of implied warranties may not apply in all cases under some statutes, and thus the above exclusion may not apply.

This document does not replace and is not intended to replace any local, state, provincial, federal, or national laws, regulations, or codes applicable to the installation and use of the battery system as well as electrical safety. Shenzhen BYD Electronics Co., Ltd. assumes no responsibility for the compliance or noncompliance with such laws or codes in connection with the installation of the battery system.

Specifications are subject to change without notice. Every effort has been made to make this document complete, accurate, and up-to-date. However, Shenzhen BYD Electronics Co., Ltd. may need to make some improvements under certain circumstances without advance notice. Shenzhen BYD Electronics Co., Ltd. shall not be responsible for any loss caused by this document, including, but not limited to, omission errors, typographical errors, arithmetical errors, or listing errors in this document.

All trademarks are recognized.

Limited Warranty

You can download the latest Limited Warranty from the internet at www.bydbatterybox.com.

Shenzhen BYD Electronics Co., Ltd.

No.1, Yan'an Road, Kuichong, Dapeng, Shenzhen, Guangdong Province, 518119, P. R. China.

Contents

| | |
|---|----|
| Legal Provisions | 1 |
| 1. Information on this Document | 5 |
| 1.1. Validity..... | 5 |
| 1.2. Target Group..... | 5 |
| 1.3. Content and Structure of this Document | 5 |
| 1.4. Declaration of Conformity | 5 |
| 1.5. Levels of Warning Messages..... | 5 |
| 1.6. Symbols in the Document..... | 6 |
| 1.7. Designation in the Document..... | 6 |
| 2. Safety..... | 7 |
| 2.1. Intended Use..... | 7 |
| 2.2. IMPORTANT SAFETY INSTRUCTIONS | 7 |
| 2.2.1. Battery Module Leakage..... | 7 |
| 2.2.2. Firefighting Measures | 8 |
| 2.2.3. Battery Modules Handling and Storage Guide | 8 |
| 2.2.4. Warning of Electric Shock..... | 9 |
| 2.2.5. Warning of Overvoltages..... | 9 |
| 2.2.6. Caution of Weight..... | 9 |
| 2.2.7. Notice of Property Damage | 10 |
| 3. Scope of Delivery..... | 11 |
| 4. Battery System Overview | 12 |
| 4.1. Battery System Description | 12 |
| 4.2. Interface..... | 13 |
| 4.3. Symbols on the System | 14 |
| 4.4. LED Signals | 16 |
| 5. Installation..... | 17 |
| 5.1. Requirements for Installation..... | 17 |
| 5.1.1. Requirements for Installation Location | 17 |
| 5.1.2. Tools..... | 18 |

| | | |
|--------|---|----|
| 5.1.3. | Safety Gear | 18 |
| 5.1.4. | Additionally Required Installation Material | 18 |
| 5.2. | Installation..... | 19 |
| 6. | Electrical Connection | 21 |
| 6.1. | Overview of the Connection Area..... | 21 |
| 6.2. | Connection Diagram..... | 23 |
| 6.2.1. | One Battery System | 23 |
| 6.2.2. | Two Battery Systems..... | 24 |
| 6.2.3. | Three Battery Systems..... | 24 |
| 6.3. | Connecting the Grounding Conductor..... | 25 |
| 6.4. | The Data Cable Connection to an Inverter | 26 |
| 6.4.1. | Connection Options | 26 |
| 6.4.2. | Connecting the Data Cable of the Inverter | 26 |
| 6.5. | Connecting the Data Cable to other Battery System(s)..... | 27 |
| 6.6. | Connecting the Network Cables..... | 30 |
| 6.7. | DC Connection | 31 |
| 6.8. | Close up | 32 |
| 7. | Commissioning..... | 33 |
| 7.1. | Switch on the Battery System..... | 33 |
| 7.2. | Configure the Battery System | 34 |
| 7.3. | Switch on and Commission the Inverter..... | 36 |
| 7.3.1. | On Grid Applications | 36 |
| 7.3.2. | Off Grid Applications..... | 37 |
| 8. | Operation | 38 |
| 8.1. | Switch on the Battery System..... | 38 |
| 8.1.1. | On Grid Applications | 38 |
| 8.1.2. | Off Grid Applications..... | 38 |
| 8.2. | Switch off the Battery System | 39 |
| 8.3. | Safety Design | 40 |
| 8.4. | Black Start Function | 40 |
| 8.5. | WLAN..... | 40 |

9. Decommissioning..... 41

10. Extension..... 42

11. Troubleshooting..... 43

 11.1. Battery System Behavior under Fault Conditions 43

 11.2. LED Light Designation for Errors..... 43

12. Maintenance and Storage..... 45

13. Disposal of the Battery System 46

14. Technical Data..... 47

15. Contact Information 49

Appendix Connection Options with Inverters 50

1. Information on this Document

1.1. Validity

This document is valid for the Battery-Box Premium HVS 5.1, 7.7, 10.2, 12.8, and HVM 8.3, 11.0, 13.8, 16.6, 19.3, 22.1 from firmware version BMU 3.16, BMS 3.24.

1.2. Target Group

The instructions in this document may only be performed by a qualified person who must have the following skills:

- Knowledge of how batteries work and are operated
- Knowledge of how an inverter works and is operated
- Knowledge of, and adherence to the locally applicable connection requirements, standards, and directives
- Knowledge of, and adherence to this document and the associated system documentation, including all safety instructions
- Trained in dealing with the hazards associated with the installation and operation of electrical equipment and batteries
- Trained in the installation and commissioning of electrical equipment

Failure to do so will make any manufacturer's warranty, guarantee or liability null, and void unless you can prove that the damage is not due to non-compliance.

1.3. Content and Structure of this Document

This document contains safety information and instructions, scope of delivery, battery system overview, installation, electrical connection, commissioning, operation, decommissioning, extension, troubleshooting, maintenance and storage, disposal of the battery system, and technical data and contact information. Please finish reading this document before taking any actions on the battery system.

1.4. Declaration of Conformity

The battery system described in this document complies with the applicable European directives. The certificate is available in the download area at www.bydbatterybox.com.

1.5. Levels of Warning Messages

The following levels of warning messages may occur when handling the battery system.

| |
|--|
|  DANGER |
| Indicates a hazardous situation which, if not avoided, will result in death or serious injury. |
|  WARNING |
| Indicates a hazardous situation which, if not avoided, could result in death or serious injury. |

| |
|--|
| ⚠ CAUTION |
| Indicates a hazardous situation which, could result in minor or moderate injury. |
| NOTICE |
| Indicates a situation which, if not avoided, could result in property damage. |

1.6. Symbols in the Document

| | |
|---------------------------|---|
| ⚠ QUALIFIED PERSON | Sections with this symbol indicates only to be performed by qualified person. |
|---------------------------|---|

1.7. Designation in the Document

| Designation in this document | Complete Designation |
|-------------------------------------|------------------------------------|
| Battery System | BYD Battery-Box Premium HVS&HVM |
| BCP | Be Connect Plus |
| BCU | Battery Control Unit |
| BIC | Battery Information Collector |
| BMS | Battery Management System |
| BMU | Battery Management Unit |
| BYD | Shenzhen BYD Electronics Co., Ltd. |
| SOC | State of Charge |

2. Safety

2.1. Intended Use

The battery system is for residential use and works with a photovoltaic system. It is a high-voltage Li-ion battery storage system, with a control module on itself. It could be operated in on-grid, off-grid and backup modes with compatible inverters.

The battery system could be connected to the internet through a network cable for maintenance and firmware updating.

The battery system must only be used as stationary equipment.

The battery system is suitable for indoor and outdoor use under the conditions mentioned in Section 5.1.

The battery system must only be operated in connection with a compatible inverter. The list (BYD Battery-Box Premium HVS & HVM Compatible Inverter List) of these inverters could be found at www.bydbatterybox.com.

The battery system is not suitable for supplying life-sustaining medical devices. Please ensure that no personal injury would occur due to the power outage of the battery system.

Alterations to the battery system, e.g., changes or modifications are not allowed unless the written permission of BYD is granted. Unauthorized alterations will void the guarantee and warranty claims. BYD shall not be held liable for any damage caused by such changes.

The type label should always be attached to the battery system.

2.2. Important Safety Instructions

The battery system has been designed and tested in accordance with international safety requirements. However, in order to prevent personal injury and property damage and ensure long-term operation of the battery system, please do read this section carefully and observe all safety information at all times.

2.2.1. Battery Module Leakage

If the battery modules leak electrolytes, contact with the leaking liquid or gas should be avoided. The electrolyte is corrosive, and the contact may cause skin irritation and chemical burns. If one is exposed to the leaked substance, please perform the following actions:

Inhalation: Evacuate the contaminated area, and seek medical help immediately.

Eye contact: Rinse eyes with flowing water for 15 minutes and seek medical help immediately.

Skin contact: Wash the affected area thoroughly with soap and water and seek medical help immediately.

Ingestion: Induce vomiting and seek medical help immediately.

2.2.2. Firefighting Measures

The battery modules may catch fire when it is put into the fire. In case of a fire, please make sure that an ABC or carbon dioxide extinguisher is nearby. Water cannot be used to extinguish the fire.

Full protective clothing and self-contained breathing apparatus are required for the firefighters to extinguish the fire.

2.2.3. Battery Modules Handling and Storage Guide

- The battery modules and their components should be protected from damage when transporting and handling.
- Do not impact, pull, drag, or step on the battery modules.
- Do not insert unrelated objects into any part of the battery modules.
- Do not throw the battery modules into the fire.
- Do not soak the battery modules in water or seawater.
- Do not expose the battery modules to strong oxidizers.
- Do not short circuit the battery modules.
- The battery modules cannot be stored at high temperatures (more than 50 °C).
- The battery modules cannot be stored directly under the sun.
- The battery modules cannot be stored in a high humidity environment.
- Do not use the battery modules if they are defective, or appears cracked, broken or otherwise damaged, or fail to operate.
- Do not attempt to open, disassemble, repair, tamper with, or modify the battery modules. The battery modules are not user-serviceable.
- Do not use cleaning solvents to clean the battery modules.

2.2.4. Warning of Electric Shock

DANGER

Danger to life due to electric shock when live components or DC cables are touched

The DC cables connected to an inverter may be live. Touching live DC cables results in death or serious injury due to electric shock.

- Disconnect the battery system and inverter from voltage sources and make sure it cannot be reconnected before working on the device.
- Do not touch non-insulated parts or cables.
- Do not remove the terminal block with the connected DC conductors from the slot under load.
- Wear suitable personal protective equipment for all work on the battery system.
- Observe all safety information of the inverter manufacturer.

2.2.5. Warning of Overvoltages

DANGER

Danger to life due to electric shock in case of overvoltages and if surge protection is missing

Overvoltages (e. g. in the event of a flash of lightning) can be further conducted into the building and to other connected devices in the same network via the network cables or other data cables if there is no surge protection. Touching live parts and cables results in death or lethal injuries due to electric shock.

- Ensure that all devices in the same network and the inverter are integrated into the existing surge protection.
- When laying the network cables or other data cables outdoors, it must be ensured that a suitable surge protection device is provided at the transition point of the cable from the battery system or the inverter outdoors to the inside of a building.

2.2.6. Caution of Weight

CAUTION

Risk of injury due to the weight of the battery module

Injuries may result if the battery module is lifted incorrectly or dropped while being transported or installed.

- Transport and lift the battery module carefully. Take the weight of the battery module into account.
- Wear suitable personal protective equipment for all work on the battery system.

2.2.7. Notice of Property Damage

NOTICE

Damage to the BCU due to sand, dust and moisture ingress

Sand, dust and moisture penetration can damage the BCU and impair its functionality.

- Only open the BCU if the humidity is within the thresholds and the environment is free of sand and dust.

NOTICE

Damage to the battery system due to under voltages

- If the battery system doesn't start at all, please contact BYD's local after-sales service team within 48 hours. Otherwise, the battery could be permanently damaged.

3. Scope of Delivery

BCU and Base Package

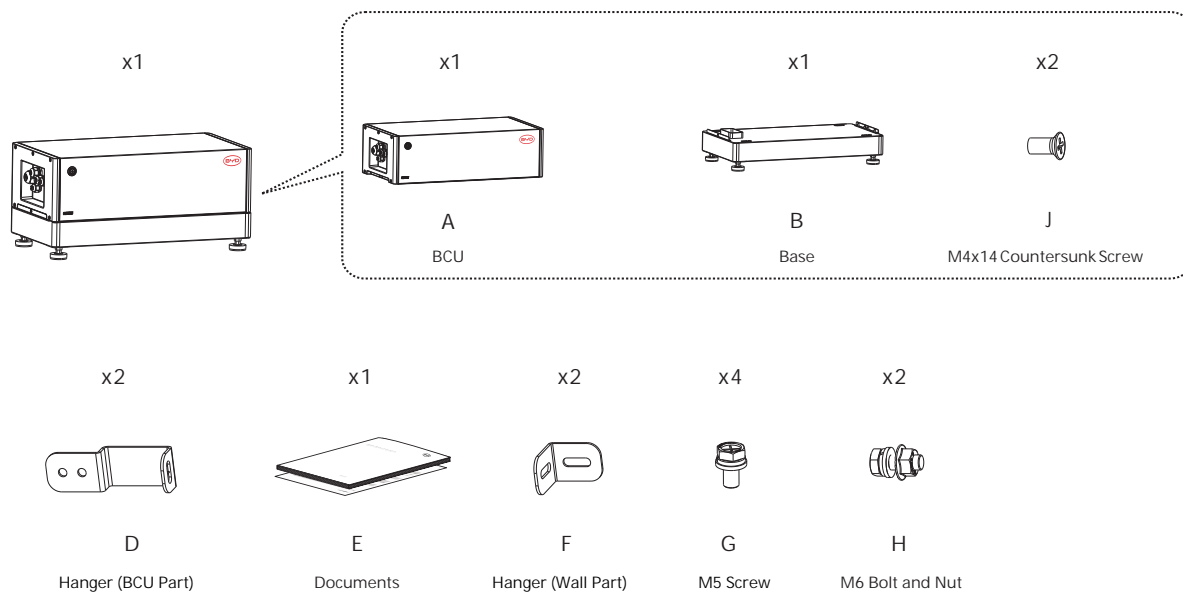

Battery Module Package

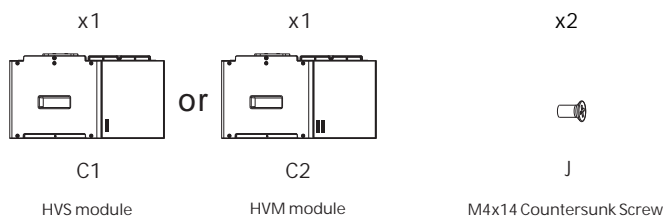

| | |
|---|--|
| A | BCU |
| B | Base |
| C | Battery module (C1 for HVS module; C2 for HVM module) |
| D | Hanger (BCU part) |
| E | Documents (Quick Start Guide, Compatible Inverter List, Service Guideline and Checklist) |
| F | Hanger (wall part) |
| G | Screw to fix D on BCU |
| H | Bolt and nut to fix D and F |
| J | Screw for fixing modules, base, and BCU together. |

4. Battery System Overview

4.1. Battery System Description

The Battery-Box Premium HVS&HVM is used as a connected battery for the intermediate storage of excess PV energy in an inverter system.

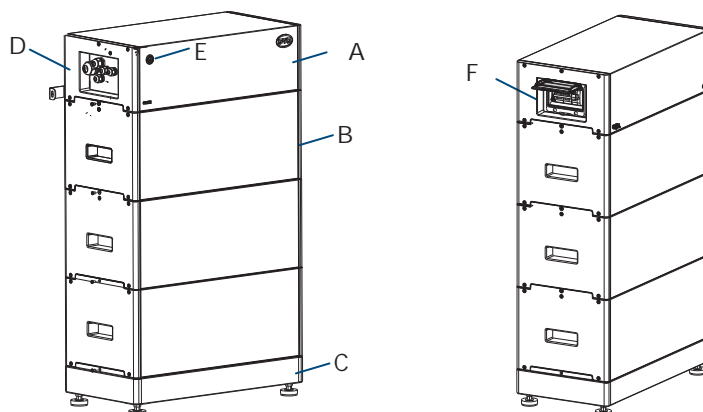

| | |
|---|-----------------|
| A | BCU |
| B | Battery module |
| C | Base |
| D | Operating panel |
| E | LED button |
| F | Air switch |

There are two types of battery modules, HVM and HVS. The HVM module has two stripes printed on it, and the HVS module has one stripe.

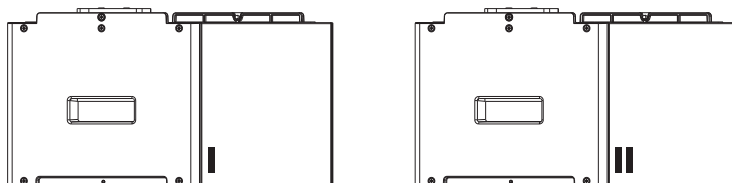

Two to five HVS battery modules or three to eight HVM battery modules could be installed in one tower. **DIFFERENT BATTERY MODULES CANNOT BE INSTALLED IN ONE TOWER.**

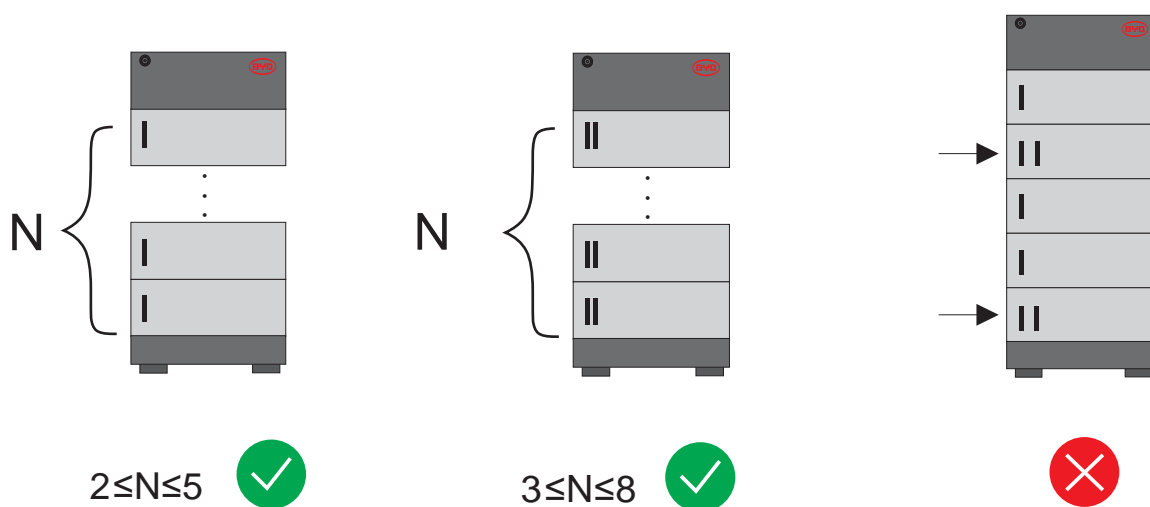

Maximum three battery systems could be connected in parallel. (This restriction does not apply for parallel connection with SMA Sunny Boy Storage 3.7-6.0. Please check the inverter operation manual on how to connect up to three battery systems.)

The HVS system cannot be connected with the HVM system.

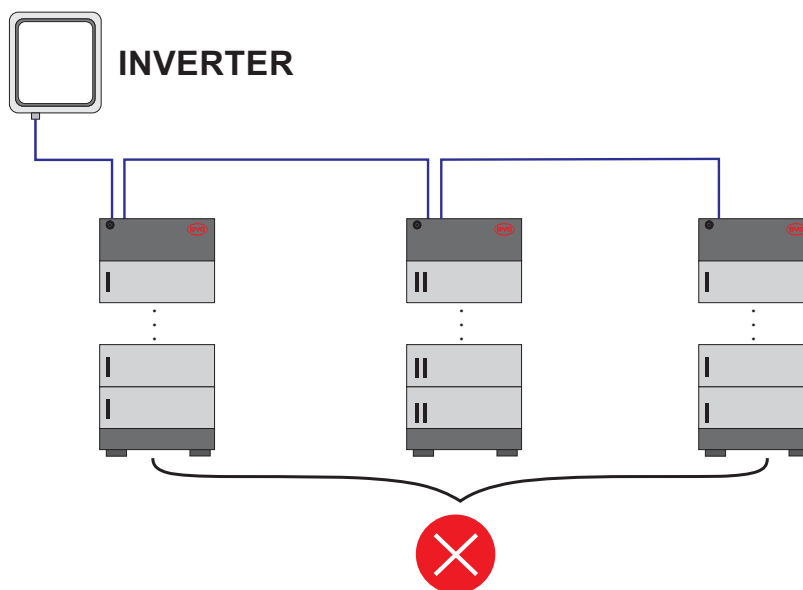

4.2. Interface

Be Connect 2.0

Be Connect 2.0 is an app for Android and iOS system devices which can be downloaded from Google Play or App Store. (Please search Be Connect 2.0 or scan the QR code on the cover of this document.)

With Be Connect 2.0, you can update the firmware, configure the battery system, read the battery status and events, upload logs to the server, etc.

Be Connect Plus









Be Connect Plus (BCP) is a PC app which can be downloaded from our website (<https://www.bydbatterybox.com/downloads>).

With BCP, you can configure and diagnose the battery system, read the general battery status information and events, update the firmware, download historical events, etc.

Be Connect Monitoring

The battery system is equipped with an "ETHERNET" port as a standard. When your battery system accesses the internet, it will join the Be Connect Monitoring, which is a platform that BYD's service team could diagnose the battery system and update firmware remotely for customers. It is highly recommended you make the internet connection available to have a better service.

4.3. Symbols on the System

| Symbol | Explanation |
|---|---|
|  | Observe the documents Observe all documents supplied with the system. |
|  | Grounding conductor This symbol indicates the position for connecting a grounding conductor. |
|  | Disposal Do not dispose of the system together with household waste. Please contact BYD's service partner (contact information at the end of this document) to dispose of it in accordance with regulations for electronic waste and used batteries. |
|  | CE marking The system complies with the requirements of the applicable EU directives. |
|  | This side up. |
|  | Handle with care. |
|  | Keep dry. |
|  | Keep the battery modules away from open flame or ignition sources. |



Beware of electrical shock.



Beware of the danger zone
This symbol indicates that the system must be additionally grounded if additional grounding or equipotential bonding is required at the installation site.



Keep the battery modules away from children.



RCM (Regulatory Compliance Mark), a marking for electrical equipment approvals in Australia.



Do not short-circuit.



The product has been tested and certified by TÜV Rheinland.

4.4. LED Signals

| | | | |
|--|--|--|---|
| <p>Blinking white and blue alternatively</p> | <p>White ○ ON OFF</p> <p>Blue ● ON OFF</p> | | <p>The battery system is initiating.</p> |
| <p>Solid white</p> | <p>White ○ ON OFF</p> <p>Blue ● ON OFF</p> | | <p>Idle the battery system is neither charging nor discharging.</p> |
| <p>Blinking white slowly</p> | <p>White ○ ON OFF</p> <p>Blue ● ON OFF</p> | | <p>The battery system is charging.</p> |
| <p>Blinking white quickly</p> | <p>White ○ ON OFF</p> <p>Blue ● ON OFF</p> | | <p>The battery system is discharging.</p> |
| <p>Blinking white and solid blue</p> | <p>White ○ ON OFF</p> <p>Blue ● ON OFF</p> | | <p>The battery system is discharging, and the SOC is below 15%.</p> |
| <p>Blinking white and blue</p> | <p>White ○ ON OFF</p> <p>Blue ● ON OFF</p> | | <p>An error has occurred refer to the service Guideline and Checklist for further details.</p> |

5. Installation

5.1. Requirements for Installation

5.1.1. Requirements for Installation Location

- a) A solid support surface must be available (e.g., concrete or masonry).
- b) The installation location must be inaccessible to children.
- c) The installation location must be suitable for the weight and dimensions of the battery system.
- d) The installation location must not be exposed to direct solar irradiation, rainwater and snow.
- e) The horizontal level of the installation site shall be above the highest water level of that area in history and at least 300 mm above the ground. The installation site must not be located in a low-lying land.
- f) The installation location must not be close to the heat sources.
- g) The altitude of the installation location should be less than 3000 m.
- h) The ambient temperature should be between -10 °C and +50 °C.
- i) The ambient humidity should be between 5-95%.

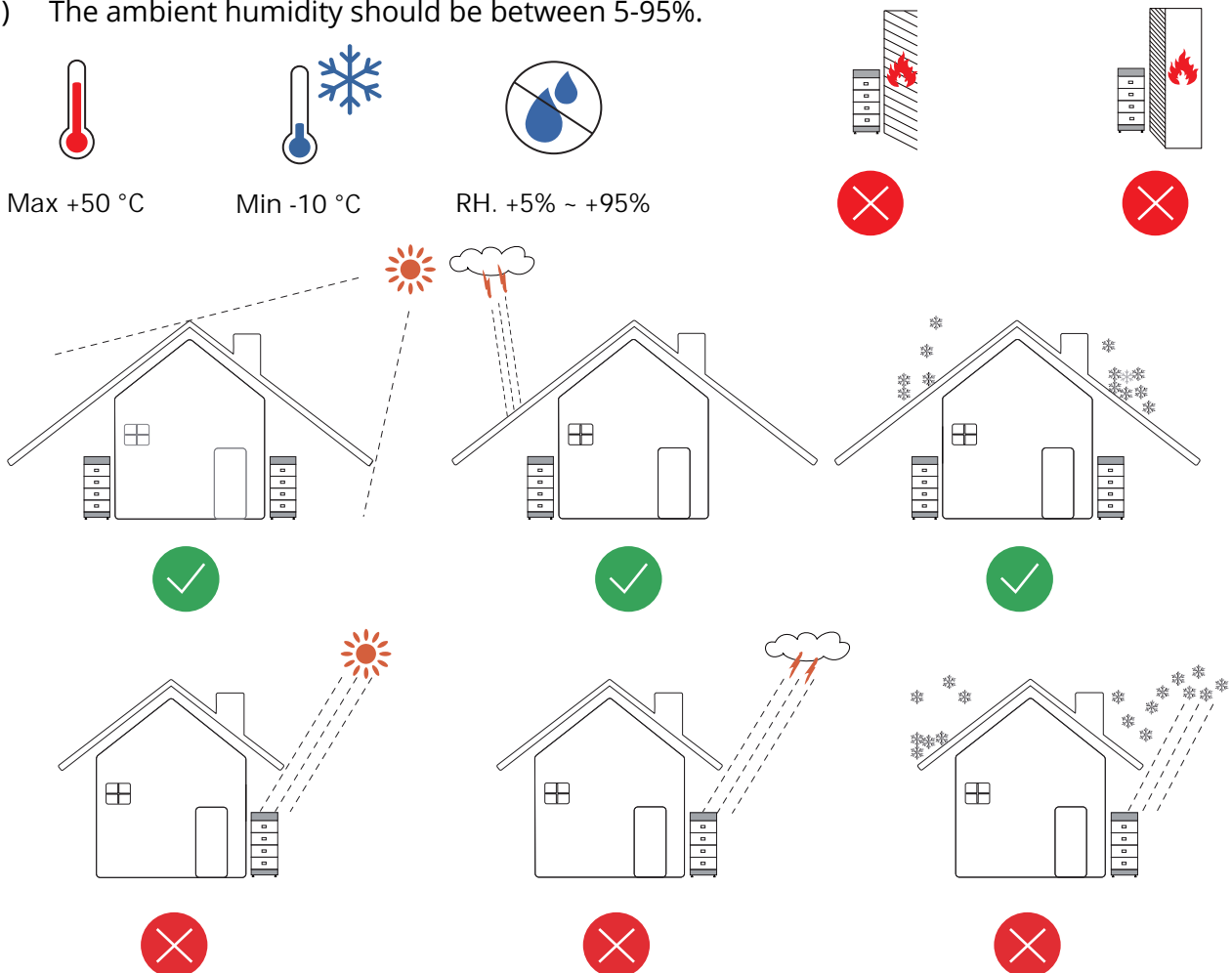

5.1.2. Tools

The tools in the following table could be needed during the installation.

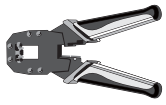

Network Wire Clamp



Pen



Phillips Screwdriver Bit



Flat-Head Screwdriver

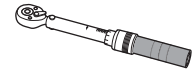

Torque Wrench

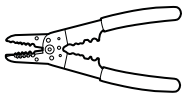

Wire Stripper

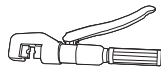

Crimping Pliers



Wrench

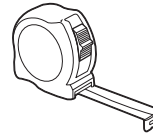

Tape Measure

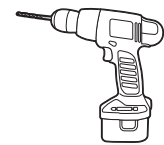

Drill



Hair Dryer

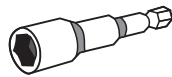

Cylinder Screwdriver

5.1.3. Safety Gear

Wear the following safety gear when dealing with the battery system.



Insulated gloves



Safety goggles



Safety shoes

5.1.4. Additionally Required Installation Materials

x2



K
DC Cable

x2

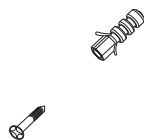

L
Expansion Anchor Bolt
(M8x40)

x1



M
Cat5 Shield

x1



N
PE Terminal

x1



O
PE Cable



P
Heat Shrink Tubing

5.2. Installation

⚠ QUALIFIED PERSON

⚠ DANGER

Danger to life due to electric shock resulting from live DC cables or connectors at the battery system

The DC cables connected to the battery system may be live. Touching the DC conductors or the live components would lead to lethal electric shocks.

- Do not touch non-insulated cable ends.

⚠ CAUTION

Risk of injury due to the weight of the battery module

Injuries may occur if the battery module is lifted incorrectly or dropped while being transported or installed.

- Transport and lift the battery module carefully. Take the weight of the battery module into account.
- Wear suitable personal protective equipment for all work on the battery system.

Additionally required installation material (not included in the scope of delivery):

- Two screws suitable for the support surface (diameter: 8 mm)
- Two screw anchors suitable for the support surface and the screws where necessary

Procedure:

1. Take the BCU and base out of the package.
2. Loose the two screws with screwdriver PH2.
3. Remove the BCU from the base.
4. Put the installed base and feet along the wall, and keep a distance of 12~19 mm between the wall and the base.
5. Take a battery module out of the package and mount it on the base. Pay attention to the direction of the module. The blind-mate connectors on the battery module and the base should be on the same side.
6. Repeat the operations for other battery modules.

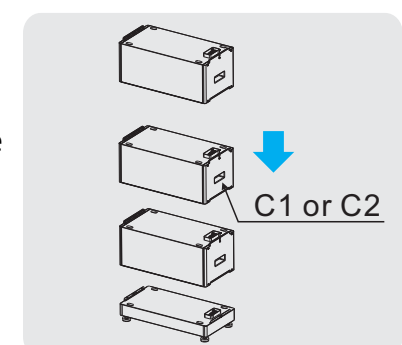
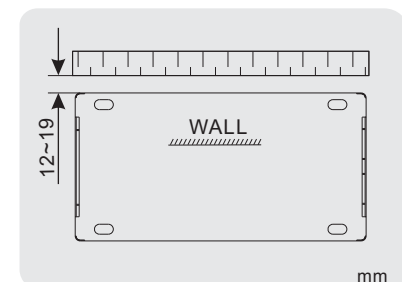
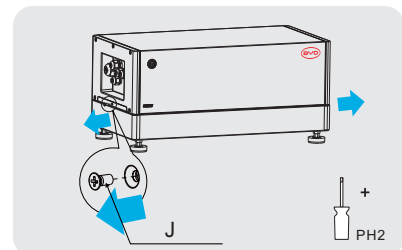

7. Install the hanger (BCU part) to the BCU with screws (M5x14) using a cylinder screwdriver (8 mm) and tighten them (torque: 5.5 Nm).

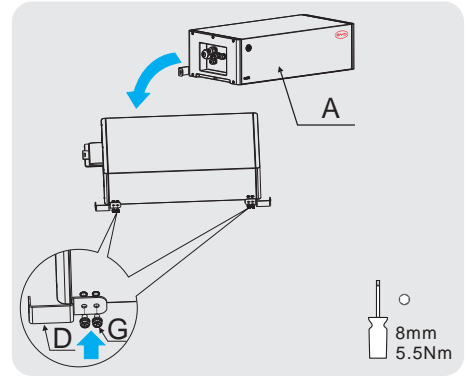

8. Mount the BCU on the top of the battery modules.

It's recommend to connect cables on the BCU first when five or more than five battery modules are needed to be installed in one tower.

9. Tighten the screws (M4x14) connecting the battery module and the base, battery modules, BCU and battery module using a Phillips screwdriver (PH2) and tighten them (torque: 2 Nm).

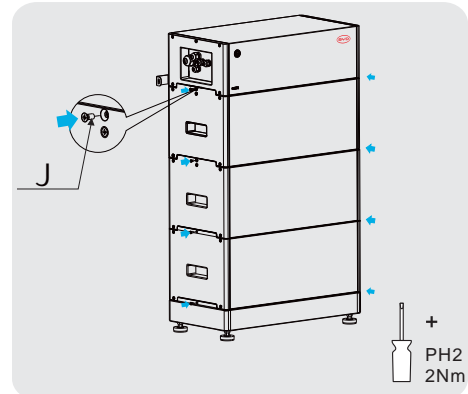

10. Hold the hanger (wall part) where it intends to be mounted on the wall and mark the position of the drill holes. Please pay attention that there may be power cables or other supply lines (e.g., gas or water) routed in the wall. Ensure that no lines are laid in the wall, which could be damaged when drilling holes.

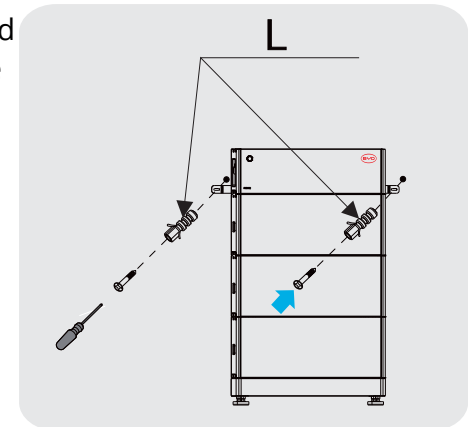

11. Put the hanger aside and drill the marked holes.

12. Insert screw anchors into the drill holes if the support surface requires them.

13. Secure the hanger using screws (M8x40 is recommended).

14. Tighten the two hangers (wall part and BCU part) with M6X16 bolts and nuts using a cylinder screwdriver (10 mm) (torque: 8 Nm).

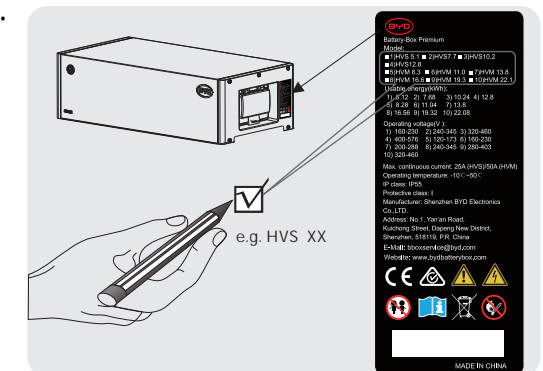

15. Mark the product type.

NOTICE

Damage to the battery system due to under voltages

- If a battery system is installed, it should be put into operation within a month, or checked regularly, otherwise there might be damage to the battery systems.

6. Electrical Connection

6.1. Overview of the Connection Area

Exterior view

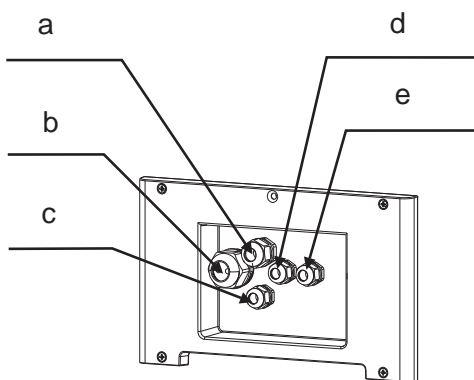

| | |
|---|--|
| a | Gland for Ethernet cable |
| b | Gland for data cable(s) to connect to an inverter and another battery system |
| c | Gland for PE |
| d | Gland for DC+ (P+) |
| e | Gland for DC- (P-) |

Interior View

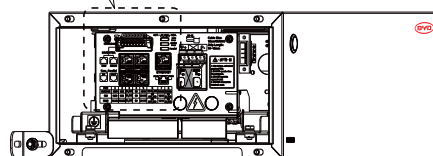
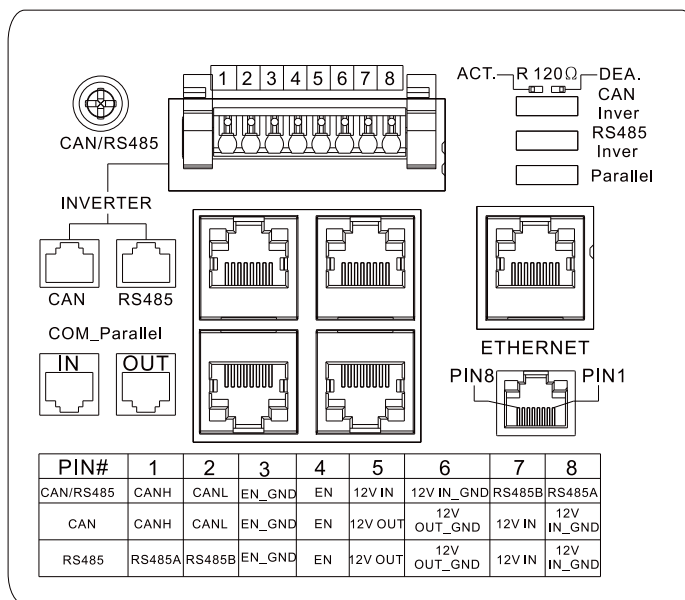

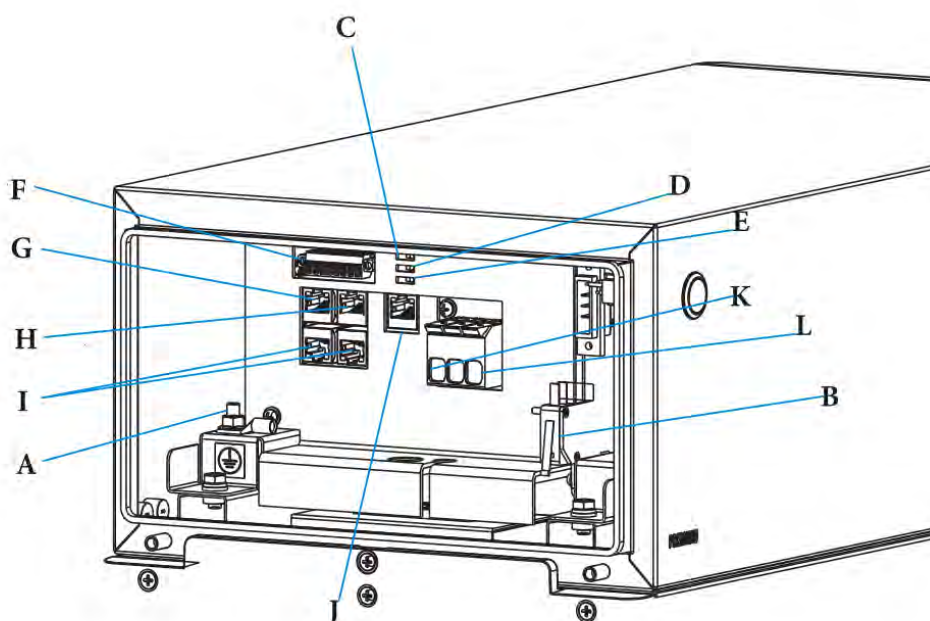

| | |
|---|---|
| A | PE connecting point |
| B | Panel open sensor |
| C | DIP switch for communication with the inverter (CAN protocol) |
| D | DIP switch for communication with the inverter (RS485 protocol) |
| E | DIP switch for communication with the other system(s) CAN protocol |
| F | 8-pin terminal blocks for connecting an inverter's data cable.(CAN or RS485 protocol) |
| G | RJ45 port for connecting an inverter's data cable (CAN protocol) |
| H | RJ45 port for connecting an inverter's data cable (RS485 protocol) |
| I | RJ45 port for connecting with other tower(s) (CAN protocol) |
| J | RJ45 port for Ethernet cable connection |
| K | DC+ to inverter |
| L | DC- to inverter |

The connection to an Ethernet cable is recommended, not compulsory.

We provide different methods to connect a inverter with the battery system. You can choose the suitable one for you.

6.2. Connection Diagram

6.2.1. One Battery System

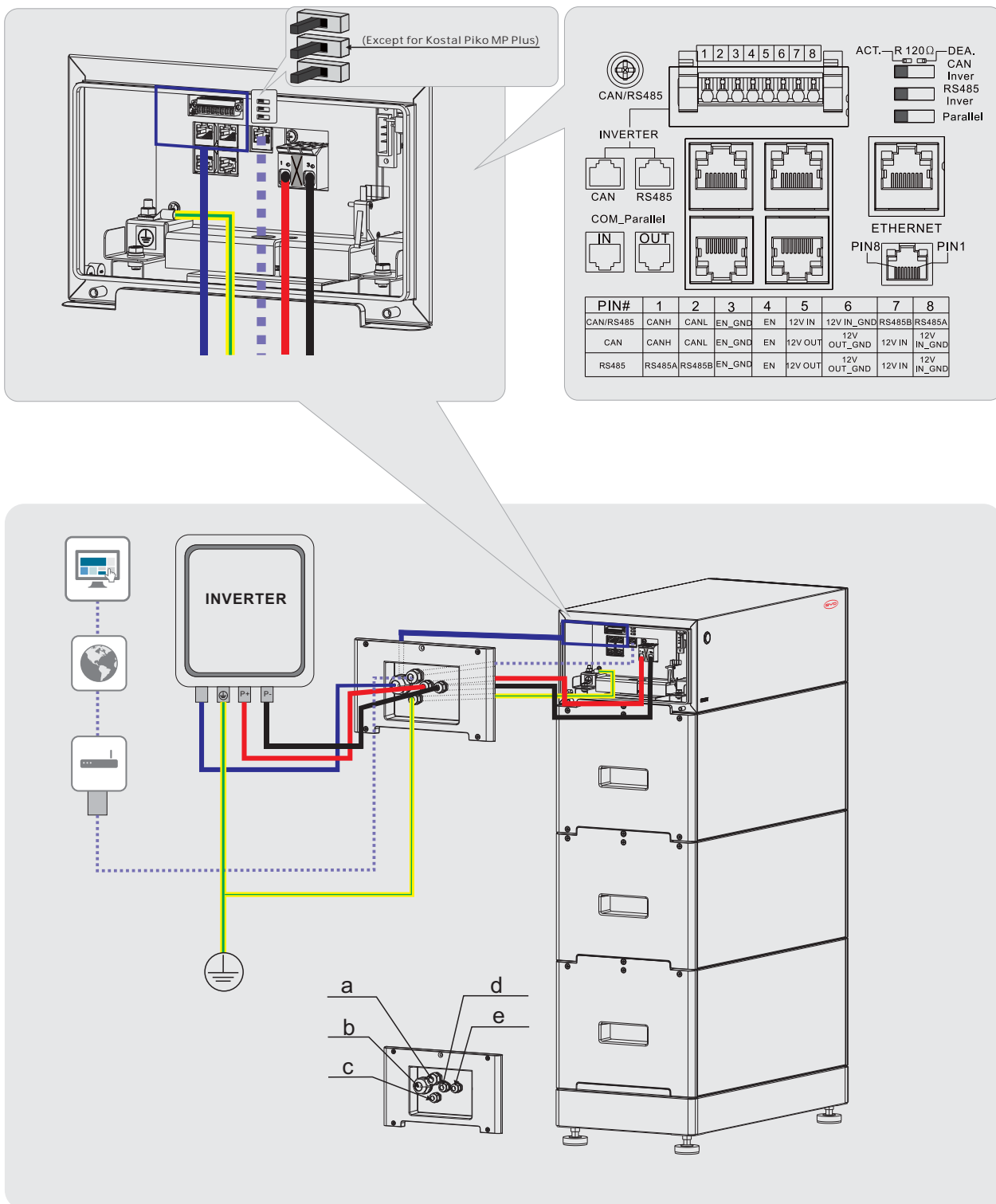

6.2.2. Two Battery Systems

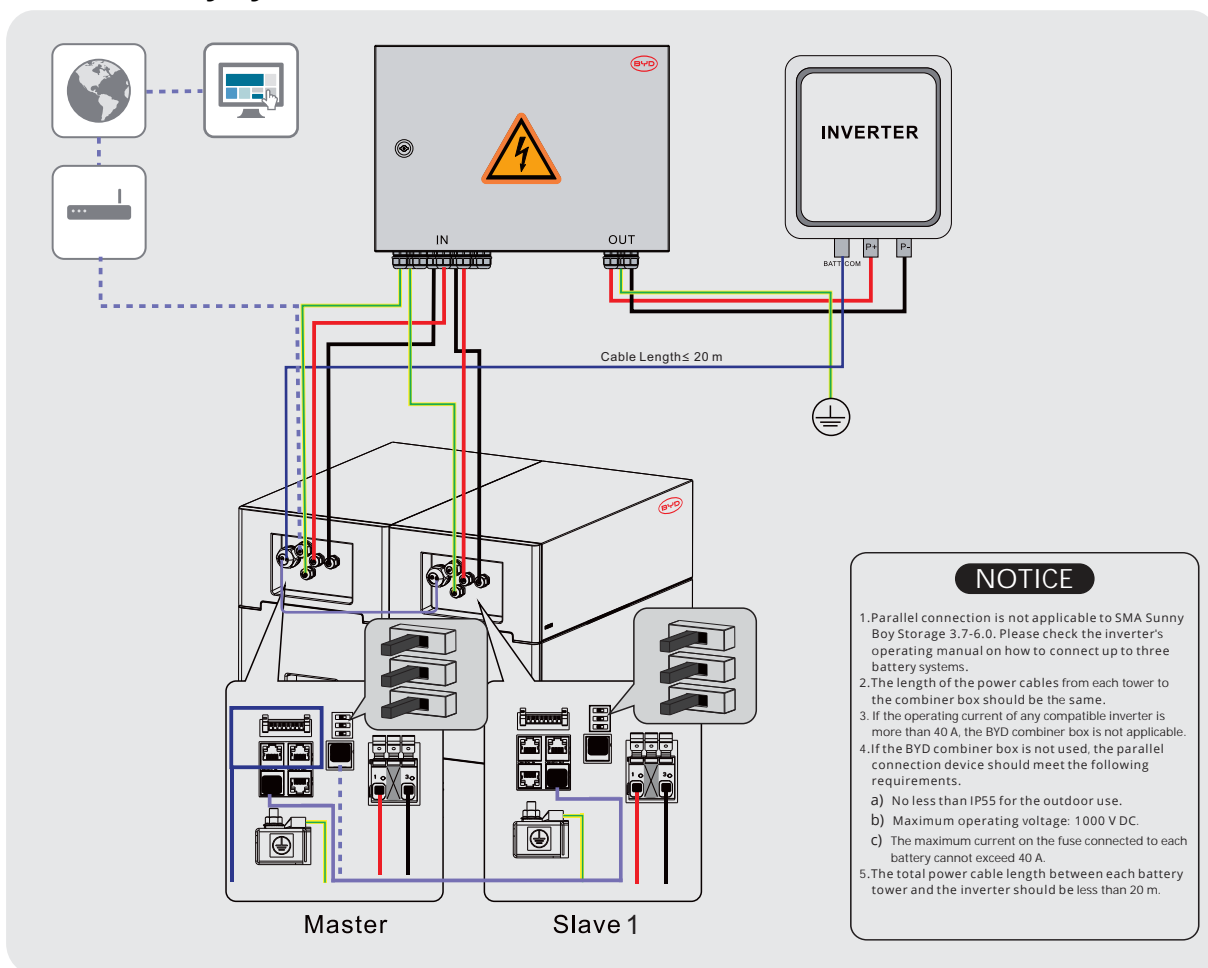

6.2.3. Three Battery Systems

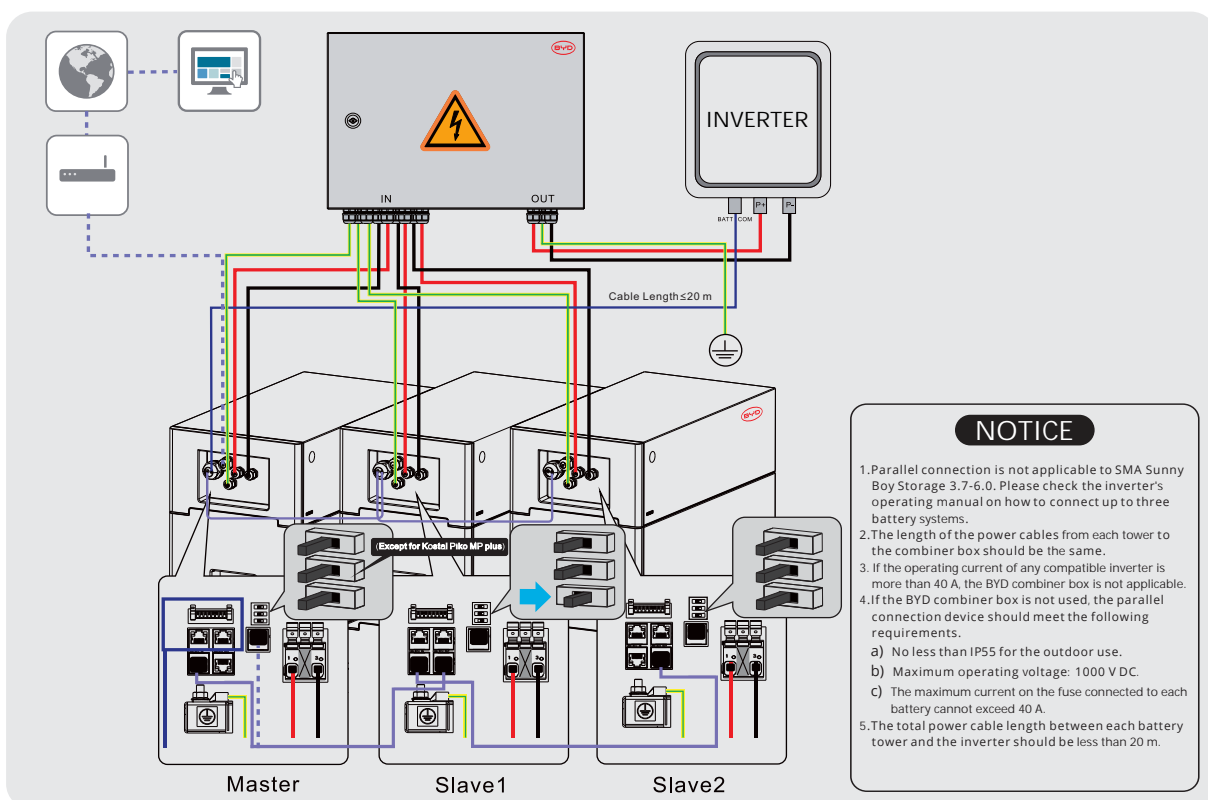

6.3. Connecting the Grounding Conductor

⚠ QUALIFIED PERSON

Additionally required mounting material (not included in the scope of delivery):

- a) Conductor SC10-5
- b) Grounding cable cross-section: 10 mm²

Note: If the maximum current of the connected inverter is no more than 40 A, a grounding cable with 6 mm² cross-section area is also acceptable.

Procedure:

1. Switch off the air switch of BCU.
2. Use a Phillips screwdriver (PH2) to take off the operating panel of BCU.
3. Remove the plug from cable gland c.
4. Take off the nut of the cable gland c.
5. Take off the cable support sleeve inside the cable gland.
6. Put the PE through the cable support sleeve.
7. Put the PE through cable gland c.
8. Strip the grounding cable and make the length (L on the right drawing) stripped 2-3 mm longer than the tube of the conductor (E on the right drawing).
9. Get the cable through the heat shrink tubing and plug the conductor on the cable.
10. Squeeze the tube of the conductor with a pair of crimping pliers.
11. Get the heat shrink tubing back to cover the connection part of the cable and the conductor.
12. Blow the heat shrink tubing with hot wind.

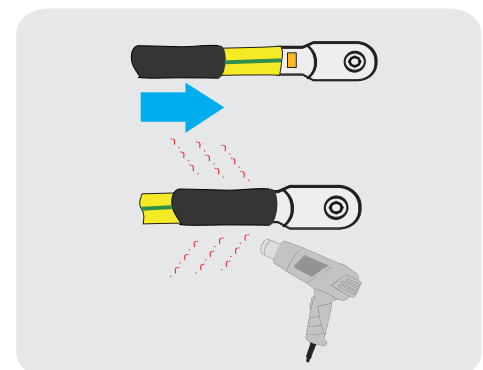
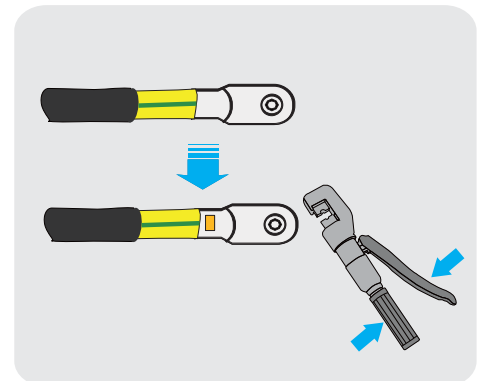
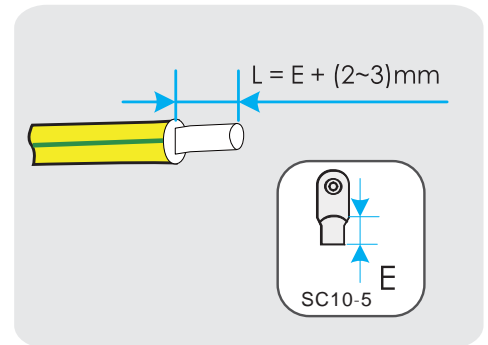
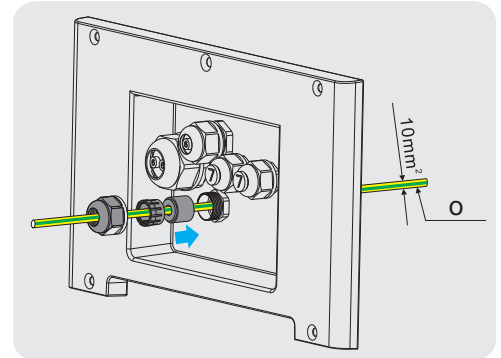

- Take the nut on the grounding point off, mount the PE conductor on, and then tighten the original nut with a cylinder screwdriver (8 mm) (torque, 4 Nm).

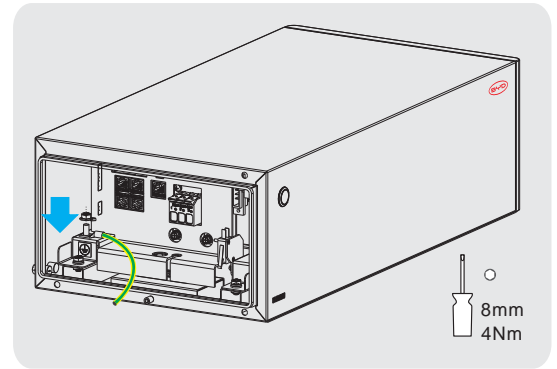

6.4. The Data Cable Connection to an Inverter

6.4.1. Connection Options

The connection options with different inverters could be read in the Appendix.

6.4.2. Connecting the Data Cable of the Inverter

⚠ QUALIFIED PERSON

Additionally required mounting material (not included in the scope of delivery):

One data cable

Data cable requirements:

The length and quality of the cable will affect the quality of the signal. Please observe the following cable requirements.

Cable category: Cat5, Cat5e or higher

Plug type: metal shielded RJ45 of Cat5, Cat5e or higher

Shielding: yes

UV-resistant for outdoor use

Straight-through wired cables

Maximum cable length: 20 m.

Procedure:

- Take off the nut of the cable gland b.
- Take off the cable support sleeve inside of the cable gland.
- Remove the plug and put the data cable through the cable support sleeve. **IF ONLY ONE HOLE OF THE CABLE GLAND B IS USED, PLEASE MAKE SURE THE OTHER HOLE IS WELL COVERED BY THE PLUG BEFORE FINISHING INSTALLATION. OTHERWISE, THE WATER HAS THE POSSIBILITY TO GET INSIDE OF THE BCU.**
- Put the data cable through cable gland b.

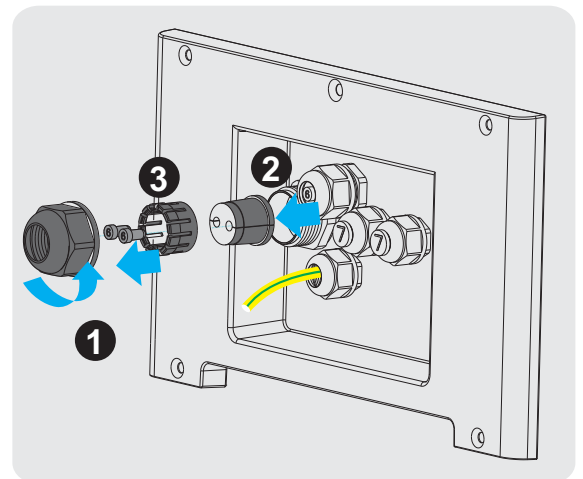

5. Plug the cable to RJ45 port or to the 8 pin terminal block.
6. Flip the corresponding DIP switch (CAN Inver or RS485 Inver) to the ACT. position (left side, which is not applicable for Kostal MP Plenticore). (Choosing CAN Inver or RS485 Inver depends on the protocol that is adapted for the inverter to communicate with the battery system.)

The method to plug the data cable into the 8 pin terminal block:

1. Strip the communication cable by 50 mm.
2. Trim the cable shield to a length of 10 mm and fold it over the cable sheath.

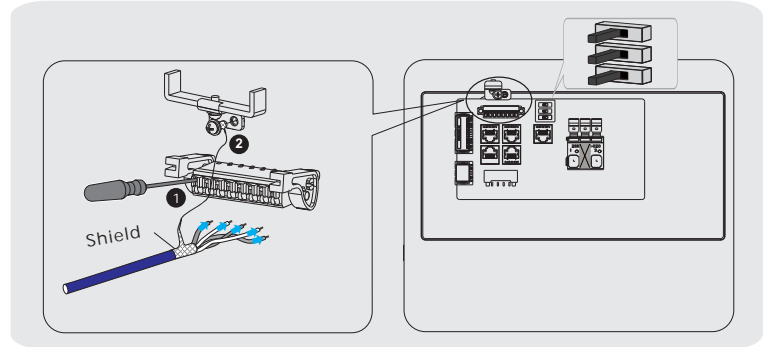

3. Strip the insulation on the insulated conductors each by 6 mm. The CAN L and CAN H (or 485a and 485b) must be a twisted pair.
4. If necessary, trim unused insulated conductors flush with the cable sheath or fold it over the cable sheath.
5. Press the button with a flat-head screwdriver, as shown in the drawing.
6. Plug the conductors into the 8 pin terminal blocks. Pay attention to the assignment of the terminal block and communication connection on the inverter.

Make sure that the conductors are plugged into the terminal points tightly by pulling slightly on the conductors.

7. Ground the shielding to the screw above.

6.5. Connecting the Data Cable to other Battery System(s)

⚠ QUALIFIED PERSON

This connection could only need to be made when two or three battery systems are connected in parallel. (The following section and restrictions do not apply for the parallel connection with SMA Sunny Boy Storage 3.7-6.0. Please check the inverter operation manual on how to connect up to three battery systems.)

The connection diagram of two battery systems could be read below.

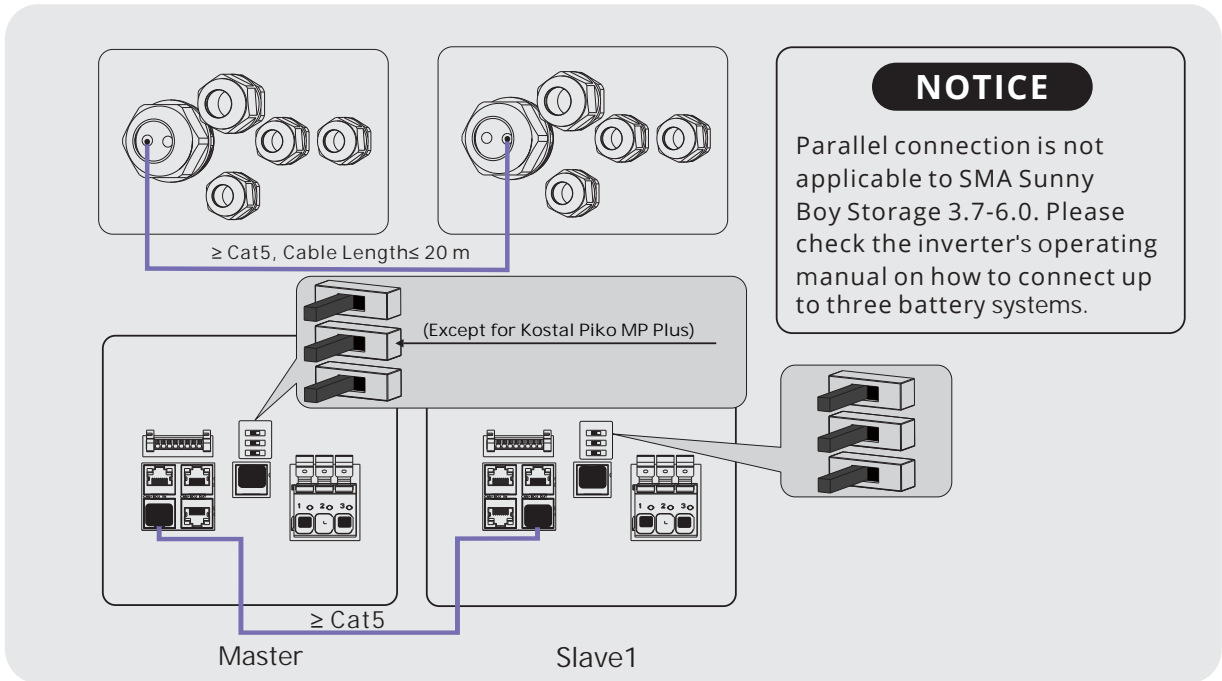

The connection diagram of three battery systems could be read below.

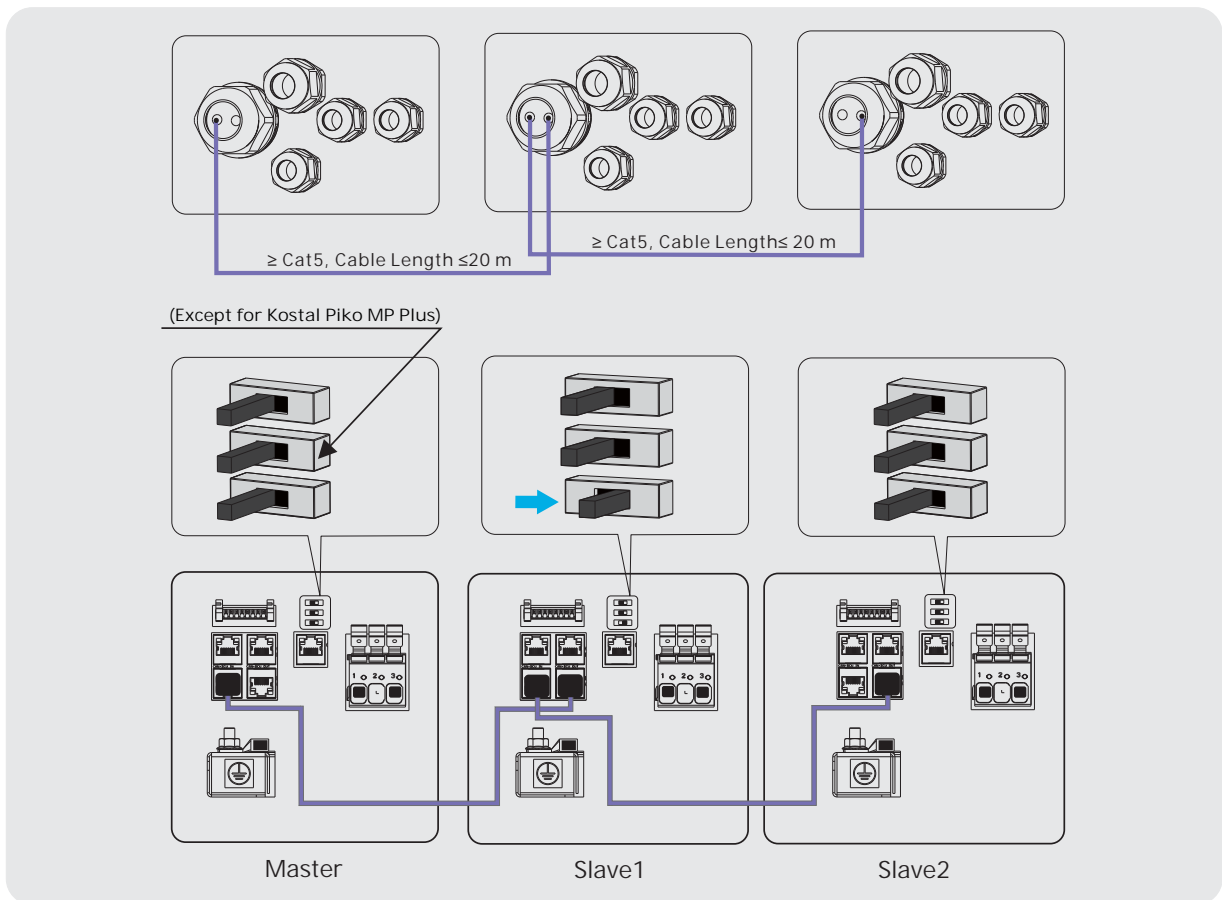

Additionally required material (not included in the scope of delivery):

- One to two data cables

Data cable requirements:

The length and quality of the cable will affect the quality of the signal. Please observe the following cable requirements.

- Cable category: Cat5, Cat5e or higher
- Plug type: metal shielded RJ45 of Cat5, Cat5e or higher
- Shielding: yes
- UV-resistant for outdoor use
- Straight- through wired cables
- Maximum cable length: 20 m.

Procedure:

1. Take off the nut of the cable gland b.
2. Take off the cable support sleeve inside of the cable gland b.
3. Remove the plug and put the data cable through the cable support sleeve. **IF ONLY ONE HOLE OF THE CABLE GLAND B IS USED, PLEASE MAKE SURE THE OTHER HOLE IS WELL COVERED BY THE PLUG BEFORE FINISHING THE INSTALLATION. OTHERWISE, THE WATER HAS THE POSSIBILITY TO GET INSIDE OF THE BCU.**
4. Put the data cable through cable gland b.
5. Plug the cable to the corresponding RJ45 port.
6. Flip the DIP switch (Parallel) according to the drawing.

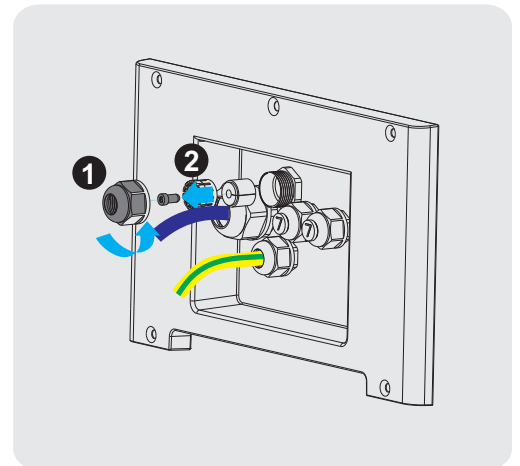

6.6. Connecting the Network Cables



Danger to life due to electric shock in case of overvoltages and if surge protection is missing

Overvoltages (e. g. in the event of a flash of lightning) can be further conducted into the building and to other connected devices in the same network via the network cables or other data cables if there is no surge protection. Touching live parts and cables results in death or lethal injuries due to electric shock.

- Ensure that all devices in the same network and the battery are integrated into the existing surge protection.
- When laying the network cables or other data cables outdoors, it must be ensured that a suitable surge protection device is provided at the transition point of the cable from the system or the inverter outdoors to the inside of a building.

The connection to the internet is not mandatory, but recommended.

Additionally required material (not included in the scope of delivery):

- One network cable (Cat5, Cat5e or higher)

Data cable requirements:

The length and quality of the cable will affect the quality of the signal. Please observe the following cable requirements.

- Cable category: Cat5, Cat5e or higher
- Plug type: metal shielded RJ45 of Cat5, Cat5e or higher
- Shielding: yes
- UV-resistant for outdoor use
- Straight-through wired cables
- Maximum cable length: 20 m.

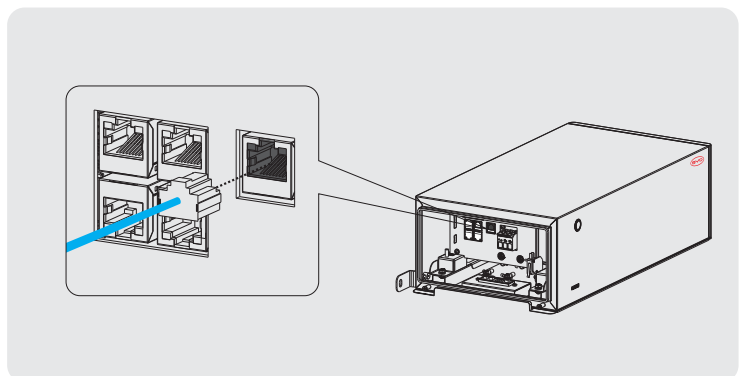

Procedure:

1. Take off the nut of the cable gland a.
2. Take off the cable support sleeve inside of the cable gland a.
3. Take out the plug and get the network cable inside of the cable support sleeve.
4. Get the network cable through cable gland a.
5. Plug the cable to the corresponding RJ45 port.

6.7. DC Connection

! DANGER

Danger to life due to electric shock resulting from live DC cables or conductors at the battery system

The DC cables connected to the battery system may be live. Touching the DC conductors or the live components would lead to lethal electric shocks.

- Do not touch non-insulated cable ends.

When two or three battery systems are connected, the positive power cable length of all the battery systems should be approximately equal, and so are the negative power cables. A junction box or Y-Bridge connectors are needed to combine these cables. You can refer to Battery-Box Premium HV Combiner Box Basic Technical Requirement, which is available at our website. Please also follow the local, state, provincial, federal, or national laws, regulations, and instructions from the inverter manufacturer to choose the right junction box or Y-Bridge connectors.

Additionally required mounting materials (not included in the scope of delivery):

Two DC power cables

Cable requirements:

- Conductor cross-section: 6 to 16 mm². The external diameter of the cable should be between 4 mm to 9 mm. Follow the requirements of the inverter manufacturer.
- Insulation stripping length: 16-18 mm
- Maximum cable length: 20 m

Procedure

1. Take off the nut of the cable glands d and e.
2. Put each cable through the cable glands d and e.
3. Push the terminal lever up.
4. Insert each conductor into the corresponding terminal point.
5. Pull the terminal lever down.
6. Ensure that the terminal points are allocated to the correct conductors.
7. Ensure that the conductors are plugged completely into the terminal points all the way to the insulation.

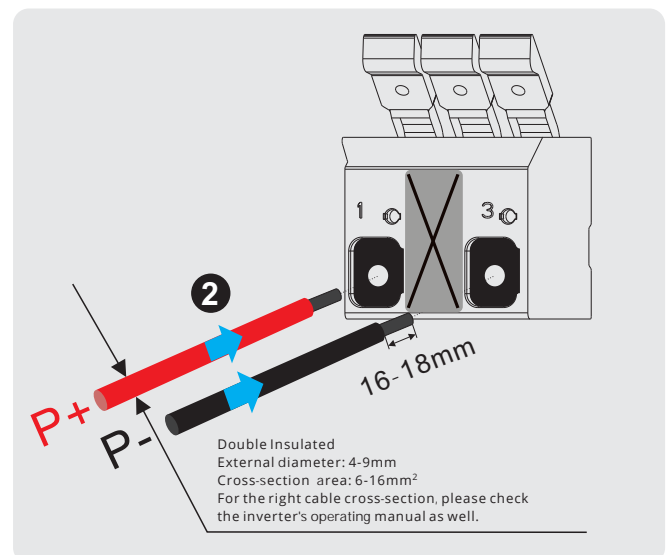

6.8. Close up

Procedure:

1. Leave a small gap between the BCU and the operating panel, so that one hand could hold data cables there.
2. Hold data cables between the BCU and the operating panel with one hand, and tighten the nuts on glands a and b with another hand.

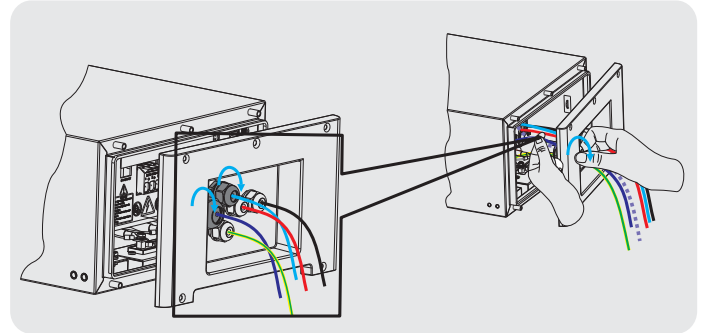

3. Tighten the screws (M4x14) to fix the operating panel using a Phillips screwdriver (PH2) (torque: 2 Nm).

PLEASE NOTE THAT IF THE OPERATING PANEL IS NOT CLOSED, THE BATTERY SYSTEM CANNOT BE SWITCH ON.

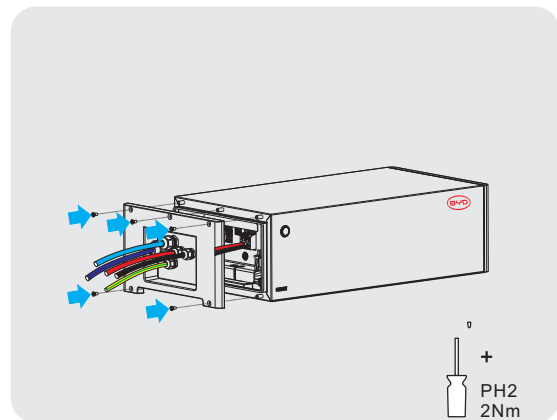

4. Tighten the nuts on cable glands c, d, and e.

PLEASE MAKE SURE THE SCREWS AND NUTS ARE FIXED WELL. FAILURE TO DO SO WILL MAKE ANY MANUFACTURER'S WARRANTY, GUARANTEE OR LIABILITY NULL AND VOID.

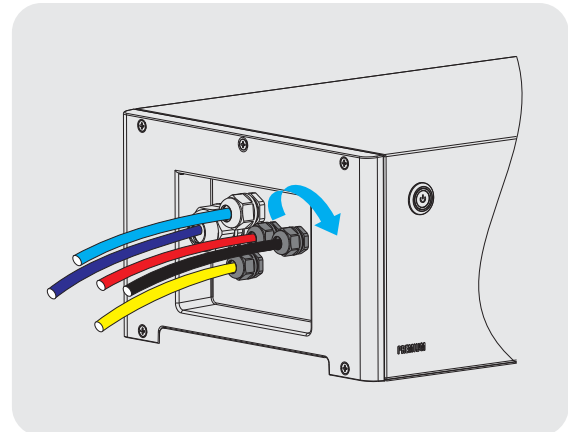

7. Commissioning

7.1. Switch on the Battery System

⚠ QUALIFIED PERSON

Requirements:

- The power cable connection between the battery system and the inverter must be off.
- The inverter must be correctly mounted.
- All cables must be correctly connected.
- The operating panel is well fixed.

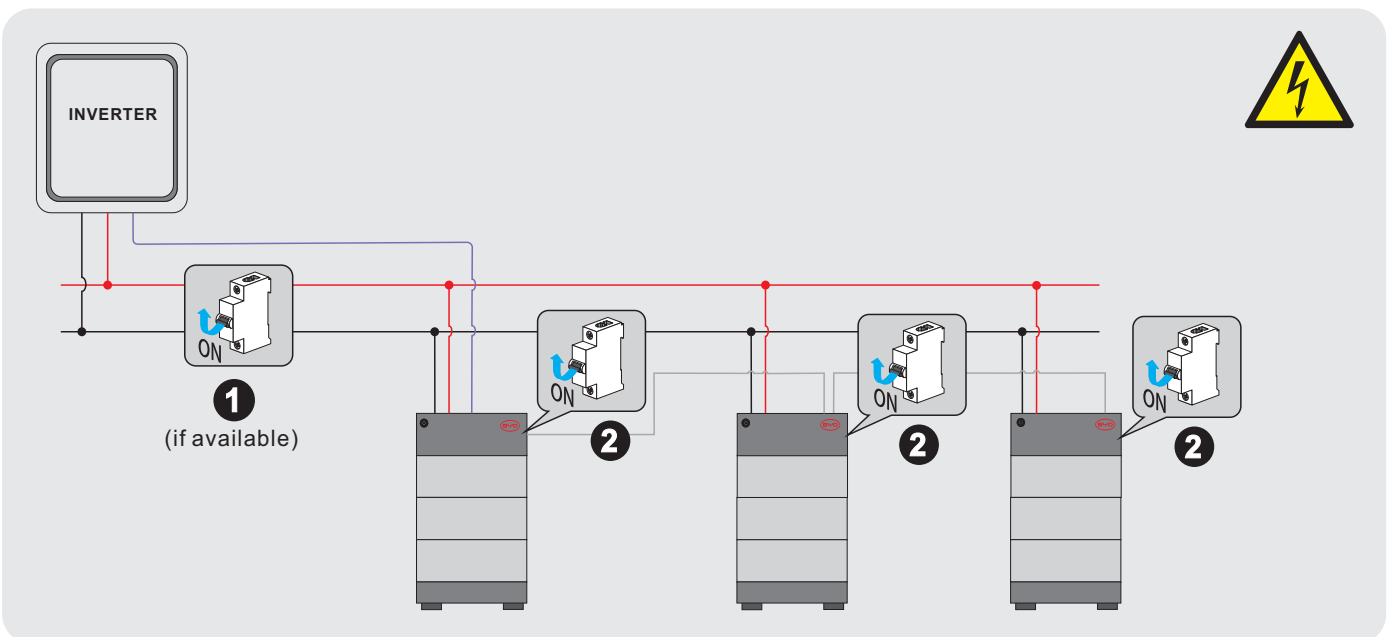

1. Switch on the air switch between the battery and inverter if there is any.
2. Open the plastic cover on the right side of the BCU.
3. Push up the air switch from the "OFF" position to "ON".
4. The LED starts to blink (0.5s white and 0.5s blue alternately) for a while, and then turns white, which means the battery system is ready to work.
5. If it failed to switch on the battery system, please read Chapter 11 Troubleshooting and also the Service Guideline and Checklist. **IF THE PROBLEM STILL CANNOT BE SOLVED, CONTACT OUR LOCAL AFTER-SALE SERVICE TEAM WITHIN 48 HOURS.**

7.2. Configure the Battery System

⚠ QUALIFIED PERSON

Procedure:

1. Download **Be Connect 2.0** from Google Play or App Store. The battery system requires the latest version of firmware to operate. So please make sure you have downloaded the latest firmware in your device (cell phone, Ipad, etc.), or your device could access the internet during configuration.
2. Tick the box in front of "I agree to the Privacy Policy", and then tap the "Start" button.
3. The app will check the firmware, and download it when the internet is available. If there is no internet available, you can tap "Skip" to skip the firmware checking.
4. After downloading the firmware, tap the button "Check WIFI Settings" to connect the Wi-Fi of the battery, which begins with "BYD-", and the full name could be found at the BCU label near the air switch.
5. The app will update the firmware automatically. After that, a notice will pop up. Tap "Yes" if you need to configure the battery system, and then tap "Next" on the "Time Confirm" page.

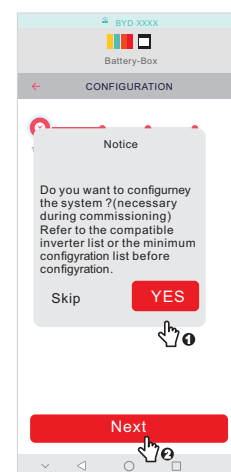
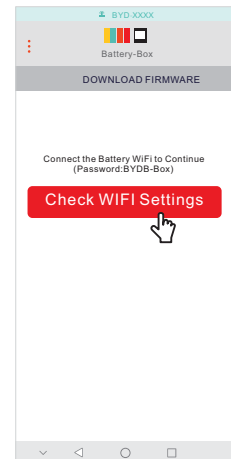
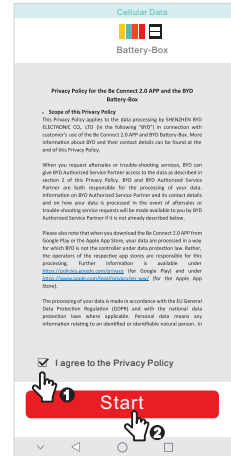

6. Choose the inverter brand which will operate together with the battery system.

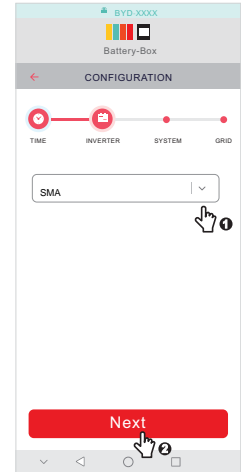

7. Choose the battery system model, HVM or HVS. (HVL is only available for the US market.) And then, set how many battery modules are installed per tower.

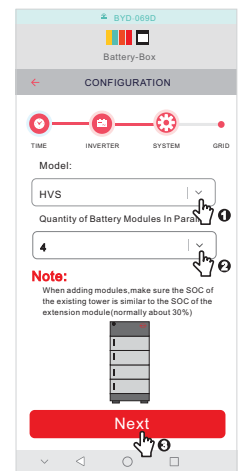

8. Check the summary of the configuration information. If no problem, tick the sentence, and tap "Next", otherwise, go back and do the configuration again.

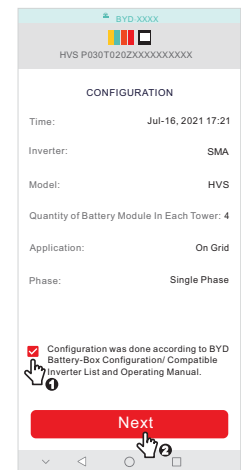

Note:

1. Restart the Be Connect 2.0 if it is stuck somewhere.
2. Please note that the SOC of the battery may not be accurate before a full charge and discharge after the configuration.

7.3. Switch on and Commission the Inverter

⚠ QUALIFIED PERSON

The procedures for on-grid and off-grid applications are different.

7.3.1. On-grid Application

Procedure:

1. Mount and connect the inverter according to the inverter manufacturer's instruction.
2. Switch on the inverter.
3. Configure the inverter and do the commissioning according to the inverter manufacturer's instruction.

If the battery information could be read correctly at the inverter, it means the connection is all right.

If the LED still blinks blue, and/or there are some battery errors shown at the inverter, please refer to the Chapter 11 Troubleshooting of this manual and also read the Service Guideline and Checklist.

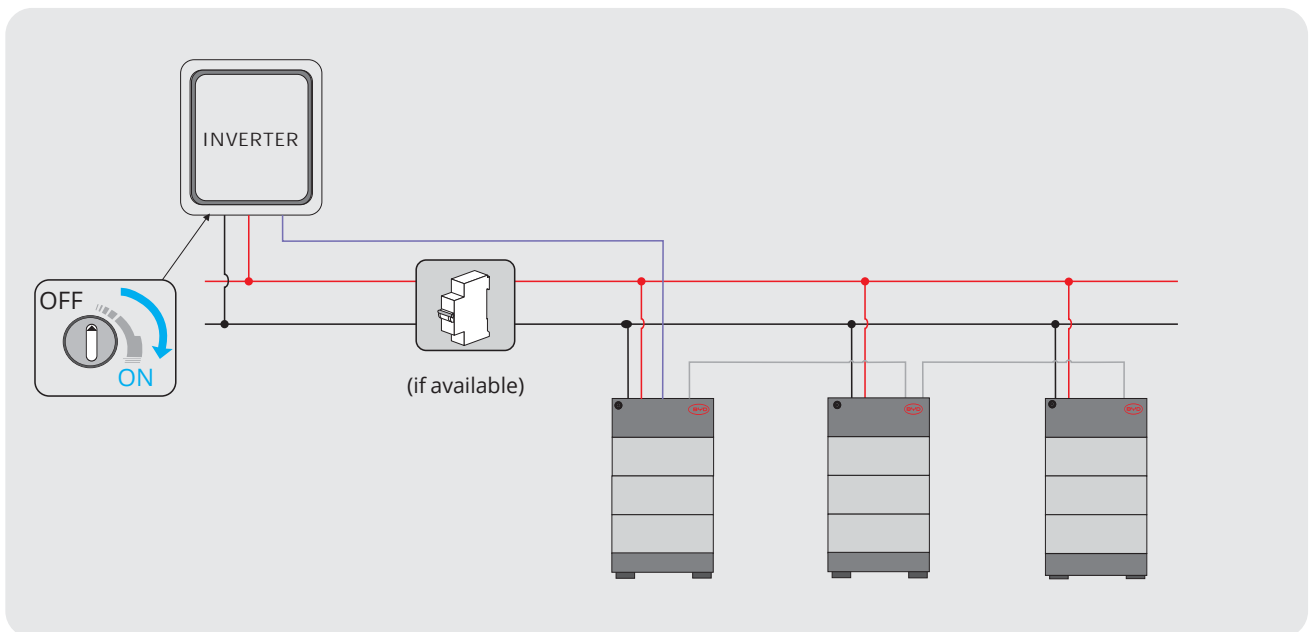

7.3.2. Off-grid Applications

Procedure:

1. Mount and connect the inverter according to the inverter manufacturer's instruction.
2. Switch on the inverter.
3. **Black start:** press the LED Button for 3 seconds on the BCU of the master System.
4. Configure the inverter and do the commissioning according to the inverter manufacturer's instruction.

If the battery information could be read correctly at the inverter, it means the connection is all right.

If the LED still blinks blue, and/or there are some battery errors shown at the inverter, please refer to Chapter 11 Troubleshooting of this manual and also read the Service Guideline and Checklist.

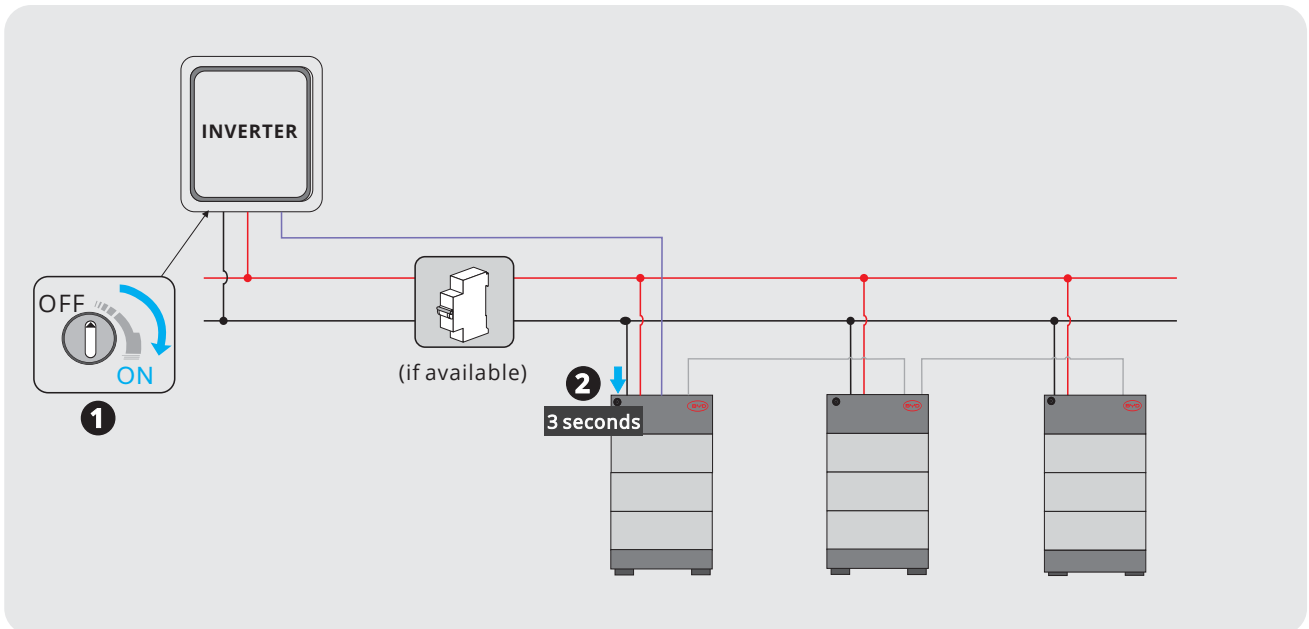

8. Operation

8.1. Switch on the Battery System

8.1.1. On-grid Applications

To make sure the battery system can work well with the inverter, please follow the right procedure to start them. The procedure is: 1) switch on the air switch between the inverter and battery if there is any; 2) switch on the battery system; 3) switch on the inverter.

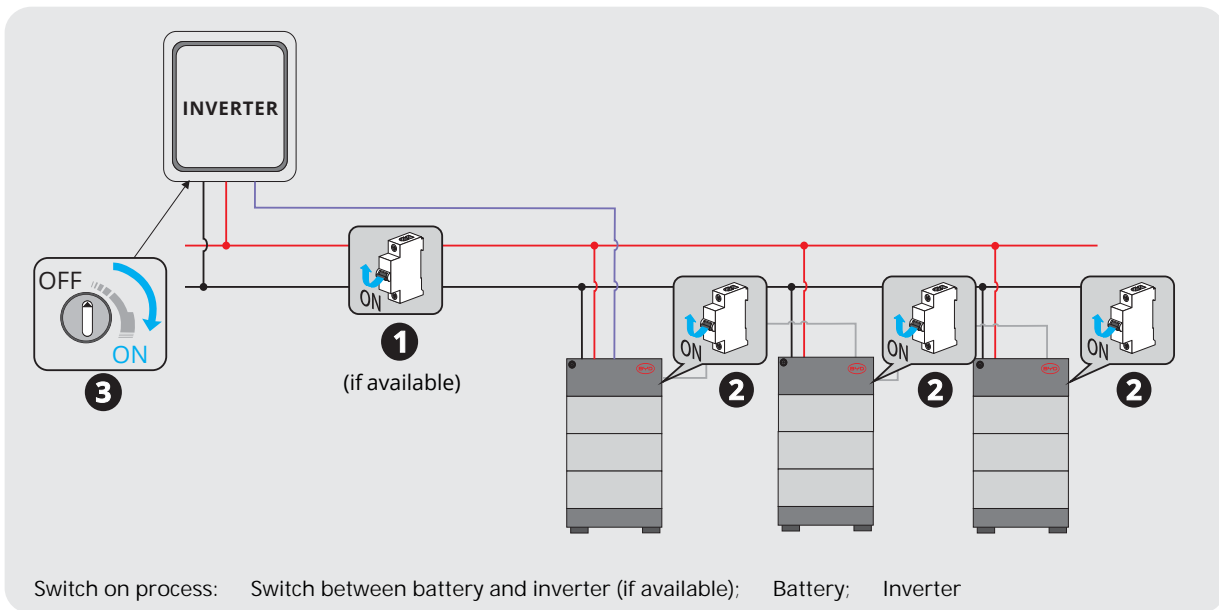

8.1.2. Off-grid Applications

To make sure the battery system can work well with the inverter, please follow the right procedure to start them. The procedure is: 1) switch on the switch between the inverter and battery if there is any; 2) switch on the battery system; 3) switch on the inverter; 4) **black start**: press the LED button of the master system for 3 seconds.

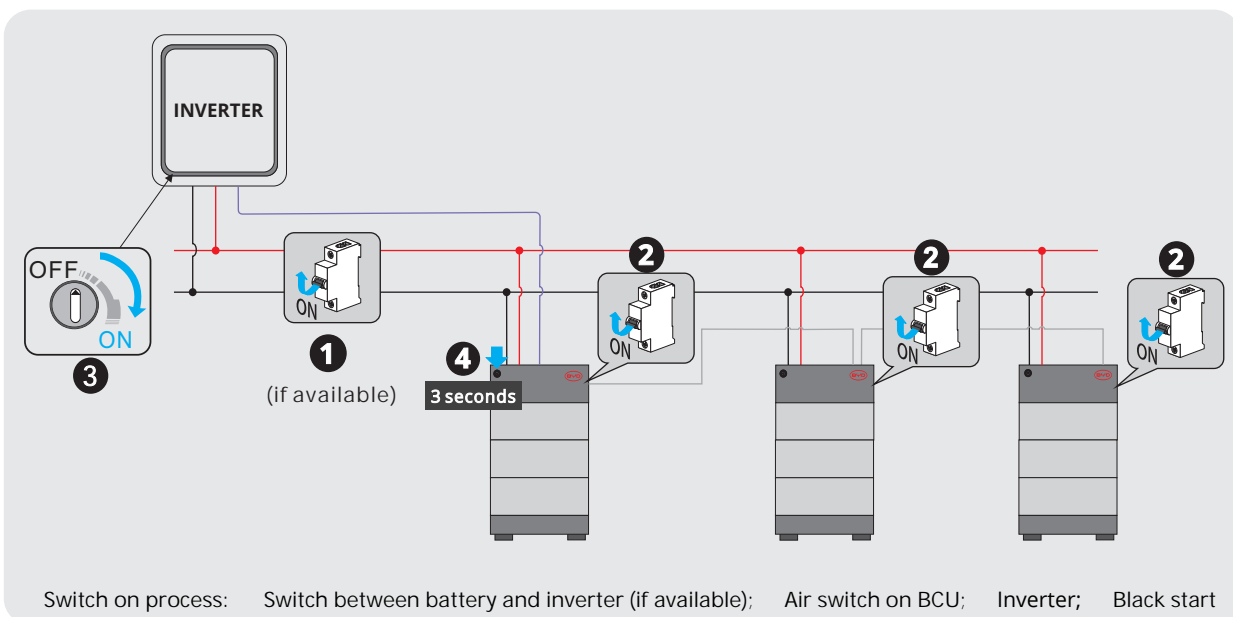

8.2. Switch off the Battery System

The procedure is: 1) switch off the inverter; 2) switch off the battery; 3) switch off the air switch between the battery and the inverter if there is any.

The correct way to switch off the battery system is to press the LED Button for 5 seconds on the BCU, but not to flip the air switch of BCU "OFF".

If two or three battery systems are connected in parallel, only the LED Button on the master system needs to be pressed. The slave system(s) will be turned off automatically.

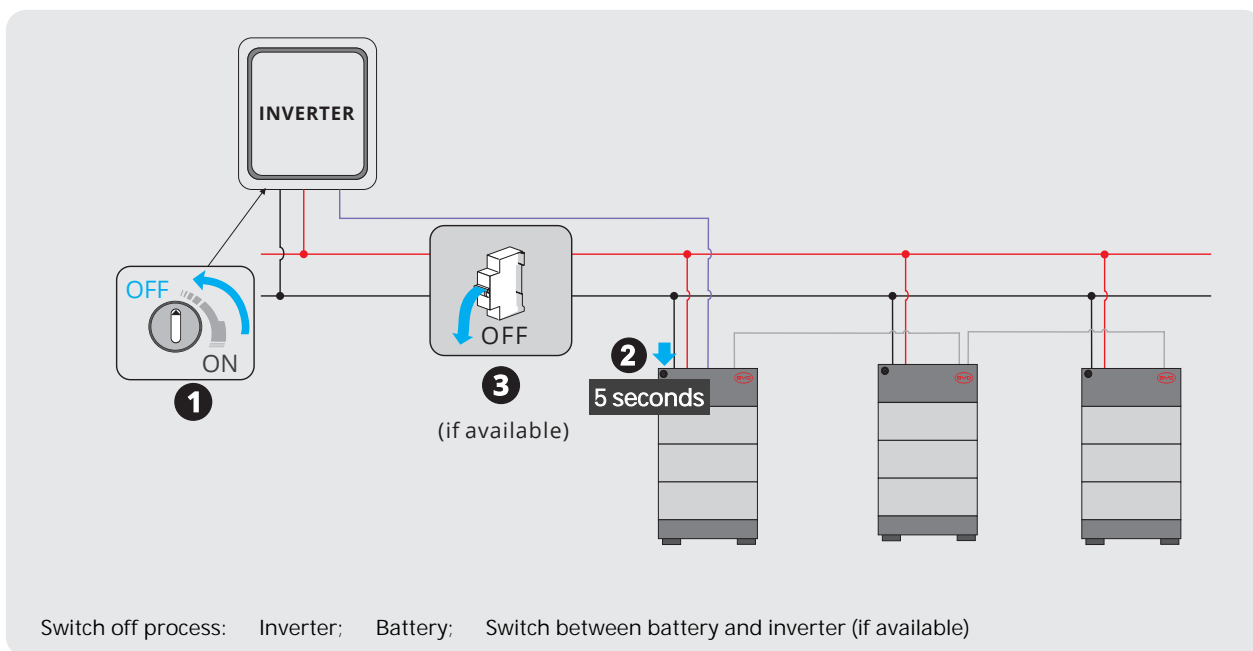

8.3. Safety Design

The battery system cannot be turned on when the operating panel is removed.

The system will switch off automatically if there is no communication with an inverter for 30 minutes or if there is an error for 10 minutes.

8.4. Black Start Function

The battery system could support the black start function of compatible inverters. The ways to trigger that are different for different inverters. Please follow the inverter manufacturer's instructions here.

8.5. WLAN

The WLAN of the battery system will be disappeared in five hours after the system started. Restart the system or press the LED button for around one second while the system is on could activate the WLAN again.

Pressing the LED button three times (each time around one second) within six seconds could reset the battery WLAN.

9. Decommissioning

QUALIFIED PERSON

DANGER

Danger to life due to electric shock resulting from live DC cables or conductors at the battery system

The DC cables connected to the battery system may be live. Touching the DC conductors or the live components would lead to lethal electric shocks.

- Do not touch non-insulated cable ends.

CAUTION

Risk of injury due to the weight of the battery module

Injuries may occur if the battery module is lifted incorrectly or dropped while being transported or installed.

- Transport and lift the battery module carefully. Take the weight of the battery module into account.
- Wear suitable personal protective equipment for all work on the battery system.

Procedure:

1. Shut off the inverter.
2. Switch off the battery system.
3. Switch off the air switch between the inverter and the battery system if there is any.
4. Take off the nuts on the cable glands on the operating panel.
5. Loose the screws on the operating panel.
6. Remove all cables from the battery system.
7. Loosen the screws on the hangers between BCU and the wall. And then take off the hangers.
8. Tighten the nuts on the cable glands on the operating panel.
9. Fix the operating panel on the BCU.
10. Remove the BCU from the battery modules and battery modules from the base.

Before lifting the battery module, ensure that the screws on both sides of them are removed.

11. Remove the hangers (BCU part).

If the battery system is to be stored or shipped, pack the system. Use the original packaging or packaging that is suitable for the weight and dimensions of the system.

Dispose of the battery system in accordance with the locally applicable battery disposal regulations for electronic waste.

10. Extension

The SOC of the existing battery system and the new battery module should be similar before the new battery module is added to the existing system.

Note: Within **5** days before extension, it is recommended to fully charge the existing battery system to SOC **100%**.

Procedure:

1. Measure the voltage of the new battery module with a multimeter, get a value (X).

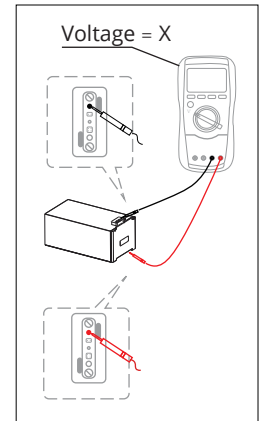

2. Refer to the following table to find out the SOC (Y) corresponding to the X.

| HVS | Voltage (X)/ V | SOC (Y) |
|------------|--------------------------|---------|
| | $X < 100.80$ | 0~5% |
| | $100.80 \leq X < 103.20$ | 5~10% |
| | $103.20 \leq X < 103.68$ | 10~15% |
| | $103.68 \leq X < 104.54$ | 15~20% |
| | $104.54 \leq X < 105.41$ | 20~25% |
| | $105.41 \leq X < 105.73$ | 25~30% |

| HVM | Voltage (X)/ V | SOC (Y) |
|------------|------------------------|---------|
| | $X < 50.32$ | 0~5% |
| | $50.32 \leq X < 51.52$ | 5~10% |
| | $51.52 \leq X < 51.74$ | 10~15% |
| | $51.74 \leq X < 52.24$ | 15~20% |
| | $52.24 \leq X < 52.64$ | 20~25% |
| | $52.64 \leq X < 52.85$ | 25~30% |

3. Charge or discharge the existing battery system until the SOC is around almost equal to Y.
4. Switch off the inverter.
5. Switch off the battery system.
6. Switch off the air switch between the inverter and the battery system if there is any.
7. Take the BCU off.
8. Add the new module on the top of the other battery modules.
9. Put BCU back on the top of the new battery module.
10. Switch on and configure the battery system.
11. Switch on the inverter.

11. Troubleshooting

Please also see the BYD Battery-Box Premium HVS/HVM Service Guideline and Checklist for troubleshooting. The latest version is available at our website www.bydbatterybox.com.

11.1. Battery System Behavior under Fault Conditions

Blue light blinking

If the LED blinks white and blue for one second each alternately, it indicates an error has occurred. (When the system is initiating, the light alternates between white and blue every 0.5s, which is not an error.)

The detailed designation for errors of LED light could be read in section 11.2.

Please note that if the communication with the inverter is not established, the blue light may blink three or eleven times. If so, check the communication with the inverter first.

Except for the LED light, BYD's service team can also get the error messages of the battery system through the remote server Be Connect Monitoring. Information read through that can help to identify the issues. It is highly recommended to connect the battery system to the internet.

NOTICE

Damage to the battery system due to under voltages

- If the battery system doesn't start at all, please contact BYD's local after-sales service team within 48 hours. Otherwise, the battery could be permanently damaged.

11.2. LED Light Designation for Errors

| | |
|-----------------------------------|---|
| Blue LED is blinking once | DC cable connection incorrect |
| Blue LED is blinking twice | A precharge transistor or relay failure |
| Blue LED is blinking three times | BIC communication failed |
| Blue LED is blinking four times | Battery sensor failure |
| Blue LED is blinking five times | BCU voltage sensor faulty |
| Blue LED is blinking six times | Current sensor failure |
| Blue LED is blinking seven times | Cell data abnormal |
| Blue LED is blinking eight times | Precharge failed |
| Blue LED is blinking nine times | BIC balancing failed |
| Blue LED is blinking ten times | Reserved |
| Blue LED is blinking eleven times | BMS and BMU communication failure |

| | |
|-------------------------------------|--------------------------------|
| Blue LED is blinking twelve times | Inverter communication failure |
| Blue LED is blinking thirteen times | Address registration failed |
| Blue LED is blinking fourteen times | System initiating failed |

12. Maintenance and Storage

Cleaning

It is recommended that the battery system be cleaned periodically. If the enclosure is dirty, please use a soft, dry brush or a dust collector to remove the dust. Liquids such as solvents, abrasives, or corrosive liquids should not be used to clean the enclosure.

Maintenance

The battery module should be stored in an environment with a temperature range between $-10^{\circ}\text{C} \sim +50^{\circ}\text{C}$, and charged regularly according to the table below with no more than 0.5 C (C-rate is a measure of the rate at which a battery is charged and discharged relative to its maximum capacity) to the SOC of 30% after a long time of storage.

| Storage environment temperature | Relative humidity of the storage environment | Storage time | SOC |
|---------------------------------|--|------------------|----------------------------------|
| Below -10°C | / | Not allowed | / |
| $-10\sim 25^{\circ}\text{C}$ | 5%~70% | ≤ 12 months | $25\% \leq \text{SOC} \leq 60\%$ |
| $25\sim 35^{\circ}\text{C}$ | 5%~70% | ≤ 6 months | $25\% \leq \text{SOC} \leq 60\%$ |
| $35\sim 50^{\circ}\text{C}$ | 5%~70% | ≤ 3 months | $25\% \leq \text{SOC} \leq 60\%$ |
| Above 50°C | / | Not allowed | / |

NOTICE

Damage to the system due to under voltages





- Charge the over-discharged system within seven days when the temperature is above 25°C .
- Charge the over-discharged system within fifteen days when the temperature is below 25°C .







13. Disposal of the Battery System

Disposal of the system must comply with the local applicable disposal regulations for electronic waste and used batteries.

- Do not dispose of the battery system with your household waste.
- Avoid exposing the batteries to high temperatures or direct sunlight.
- Avoid exposing the batteries to high humidity or corrosive atmospheres.
- For more information or to arrange a collection please contact BYD Service Partner (see contact details at the bottom of this document).

14. Technical Data

| |  |  |  |  |
|------------------------------------|---|---|---|---|
| | HVS 5.1 | HVS 7.7 | HVS 10.2 | HVS 12.8 |
| Battery Module | HVS (2.56 kWh, 102.4 V, 38 kg) | | | |
| Number of Modules | 2 | 3 | 4 | 5 |
| Usable Energy ^[1] | 5.12 kWh | 7.68 kWh | 10.24 kWh | 12.8 kWh |
| Max Output Current ^[2] | 25 A | 25 A | 25 A | 25 A |
| Peak Output Current ^[2] | 50 A, 3 s | 50 A, 3 s | 50 A, 3 s | 50 A, 3 s |
| Nominal Voltage | 204.8 V | 307.2 V | 409.6 V | 512 V |
| Operating Voltage | 160~240 V | 240~360 V | 320~480 V | 400~600 V |
| Dimensions (H/W/D) | 762X 585x 298 mm | 995x 585x 298 mm | 1228x 585x 298 mm | 1461X 585X 298 mm |
| Weight | 91 kg | 129 kg | 167 kg | 205 kg |
| Battery Designation | IFpP/21/173/120/32S/M/-10+50/90 | | | |

| |  |  |  |  |  |  |
|------------------------------------|---|---|---|--|---|---|
| | HVM 8.3 | HVM 11.0 | HVM 13.8 | HVM 16.6 | HVM 19.3 | HVM 22.1 |
| Battery Module ^[3] | HVM (2.76 kWh, 51.2 V, 35/ 38 kg) | | | | | |
| Number of Modules | 3 | 4 | 5 | 6 | 7 | 8 |
| Usable Energy ^[1] | 8.28 kWh | 11.04 kWh | 13.80 kWh | 16.56 kWh | 19.32 kWh | 22.08 kWh |
| Max Output Current ^[2] | 50 A | 50 A | 50 A | 50 A | 50 A | 50 A |
| Peak Output Current ^[2] | 75 A, 3 s | 75 A, 3 S | 75 A, 3 s | 75 A, 3 s | 75 A, 3 s | 75 A, 3 s |
| Nominal Voltage | 153.6 V | 204.8 V | 256 V | 307.2 V | 358.4 V | 409.6 V |
| Operating Voltage | 120~177 V | 160~236 V | 200~295 V | 240~354 V | 280~413 V | 320~472 V |
| Dimensions (H/W/D) | 995x 585X 298 mm | 1228X 585X 298 mm | 1461X 585X 298 mm | 1694X 585X 298 mm | 1927X 585X 298 mm | 2160X 585X 298 mm |
| Weight ^[4] | 119~129 kg | 153~167 kg | 188~205 kg | 222~243 kg | 257~281 kg | 291~319 kg |
| Battery Designation | IFpP/47/174/120/16S/M/-10+50/90 | | | | | |

| HVS & HVM | |
|-----------------------------|---------------------------------------|
| Operating Temperature | -10 °C to +50 °C |
| Battery Cell Technology | Lithium Iron Phosphate (cobalt-free) |
| Communication | CAN/ RS485 |
| Enclosure Protection Rating | IP55 |
| Round-trip Efficiency | ≥ 96% |
| Certification | VDE2510-50/ IEC62619/ CEC/ CE/ UN38.3 |
| Applications | ON Grid/ ON Grid+Backup/ OFF Grid |
| Warranty ^[5] | 10 Years |

- [1] DC Usable Energy, test conditions: 100% DOD, 0.2 C charge & discharge at +25 °C. System Usable Energy may vary with different inverter brands.
- [2] Charge derating will occur between -10 °C and +5 °C.
- [3] HVM module has two versions with two types of cells applied separately. Both versions share the same performance, only weights differ.
- [4] Two versions of HVM module are adaptable with each other and can be stacked in one tower. The weights of the tower may vary with mixed HVM modules.
- [5] Conditions apply. Refer to BYD Battery-Box Premium Limited Warranty Letter.

15. Contact Information

Note: Please also see the Battery-Box Premium HVS/HVM Service Guideline and Checklist for troubleshooting. The latest version is available at our website: www.bydbatterybox.com.

BYD Global Service

| | |
|-------------------|--|
| Email | bboxservice@byd.com |
| Telephone | +86 755 89888888-47175 |
| Address | No.3009, BYD Road, Pingshan, Shenzhen, 5118118, P. R. China |
| Website | www.bydbatterybox.com https://www.facebook.com/BatteryBoxBYD |
| Social Media Link | https://x.com/BYD_BatteryBox https://www.linkedin.com/company/byd-batthey-box |

Europe

EFT-Systems GmbH

| | |
|-----------|--|
| Email | service@eft-systems.de +49 9352 8523999 |
| Telephone | +44 (0) 2037695998 (UK) +34 91 060 22 67 (ES) +39 02 87368364 (1T) |
| Address | Bruchtannenstr. 28, 63801 Kleinostheim, Germany |
| Website | www.eft-systems.de |

Australia

Alps Power Pty Ltd

| | |
|-----------|--|
| Email | service@alpspower.com.au |
| Telephone | +61 2 8005 6688 |
| Address | 2/62 Belmore Road, Riverwood, NSW 2210 |
| Website | www.alpspower.com.au |

South Africa

Afriplus Energy Group (Pty) Ltd

| | |
|-----------|--|
| Email | support@afriplusenergy.co.za |
| Telephone | +27 21 140 3594 |
| Address | The Pavilion, Corner Of Dock & Portswood Road, V&A Waterfront, 8001, Cape Town |
| Website | www.afriplusenergy.co.za |

USA

BYD US Service

| | |
|-----------|--|
| Email | us.homeenergy@byd.com |
| Telephone | 626-491-2333 |
| Address | 888 E Walnut St, Suite 200A, Pasadena, CA 91101, USA |

Appendix Connection Options with Inverters

Before the installation, please first check if the planned configuration is already released according to the latest Battery-Box Premium HVS/HVM Compatible Inverter List.

1 SMA SBS 2.5/ 3.7/ 5.0/ 6.0 Option a

Battery-Box SMA

| Pin | Pin |
|-----|-----|
| 4 | B |
| 3 | C |
| 2 | D |
| 1 | E |

Cable Lengths ≤ 20m

NOTICE

Parallel connection is not applicable to SMA Sunny Boy Storage 3.7-6.0. Please check the inverter Operating Manual on how to connect up to three battery systems.

2 SMA SBS 2.5/ 3.7/ 5.0/ 6.0 Option b

Battery-Box SMA

| Pin | Pin |
|-----|-----|
| 4 | B |
| 3 | C |
| 2 | D |
| 1 | E |

Cable Lengths ≤ 20m

Shield

3 SMA STP 5.0-10.0 SE Option a

Battery-Box

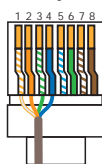

Battery-Box SMA

| Pin | Pin |
|-----|-----|
| 1 | 1 |
| 2 | 3 |
| 3 | 4 |
| 4 | 2 |

SMA

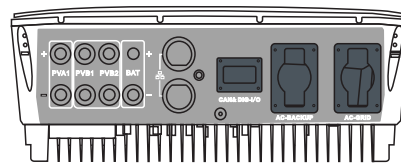
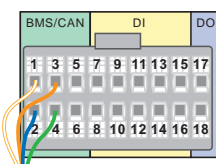

Cable Length ≤ 20 m

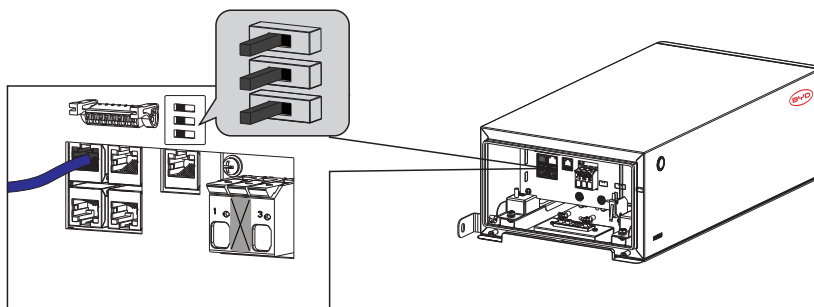

4 SMA STP 5.0-10.0 SE Option b

Battery-Box

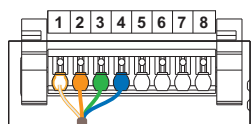

Battery-Box SMA

| pin | pin |
|-----|-----|
| 1 | 1 |
| 2 | 3 |
| 3 | 4 |
| 4 | 2 |

SMA

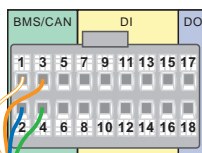

Cable Length ≤ 20 m

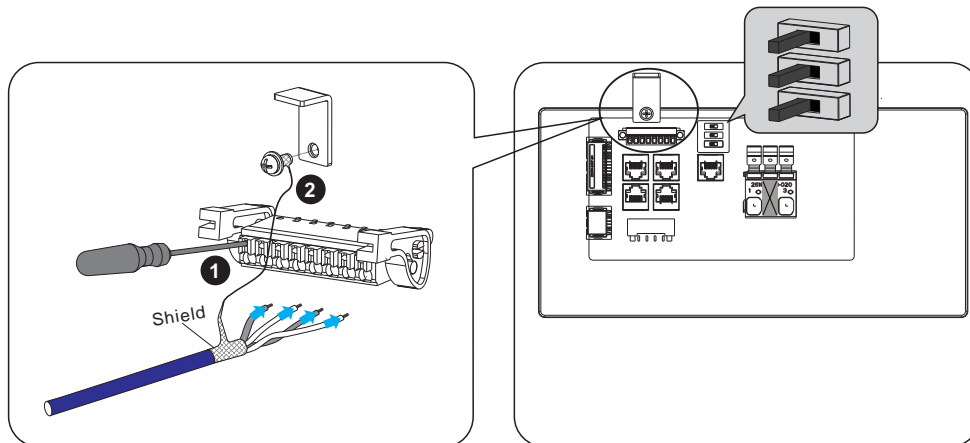

5 SMA SBSE 3.6 / 4.0 / 5.0 / 6.0 Option a

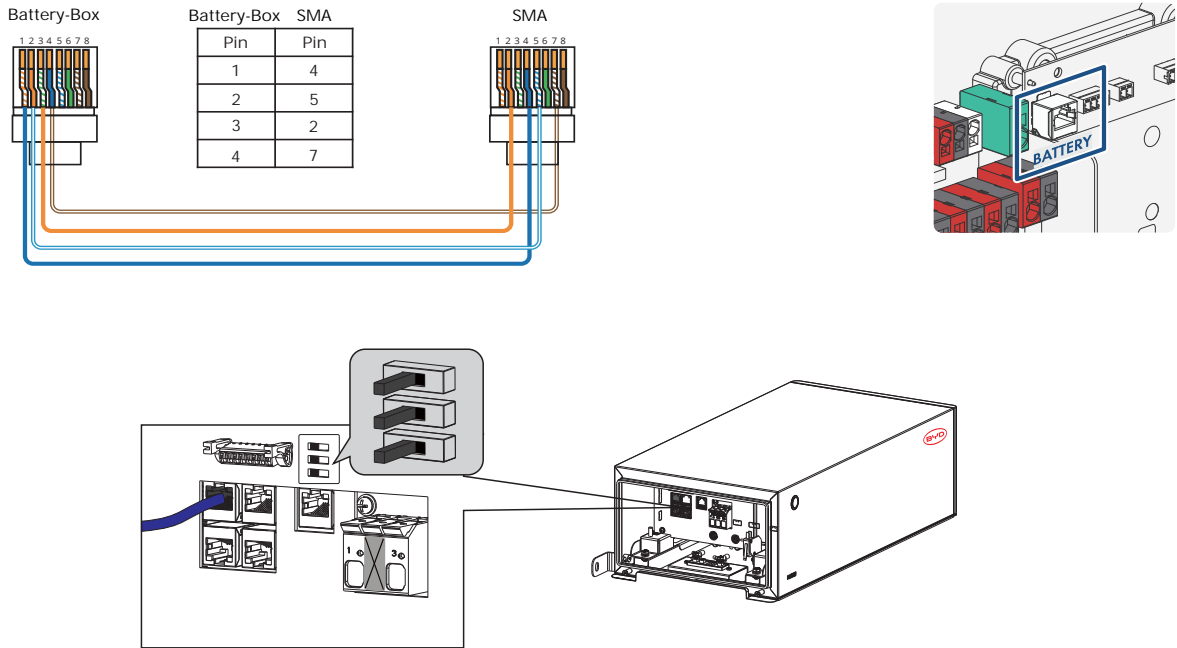

6 SMA SBSE 3.6 / 4.0 / 5.0 / 6.0 Option b

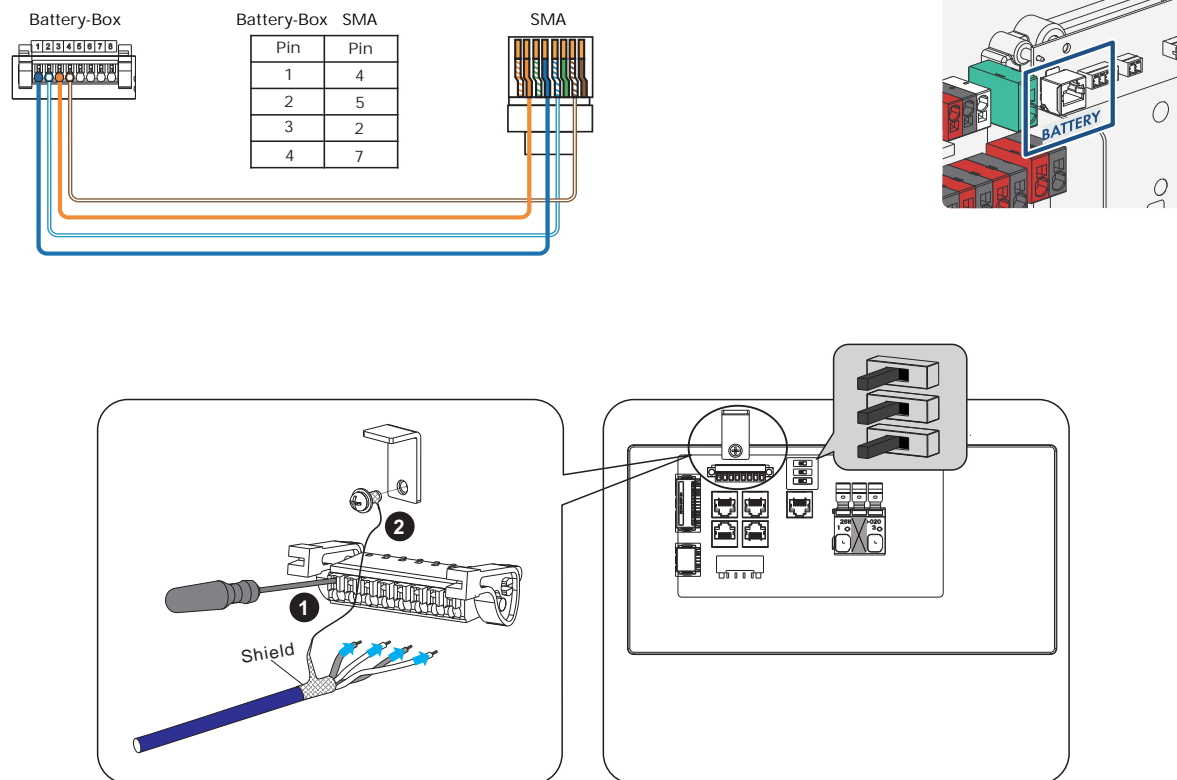

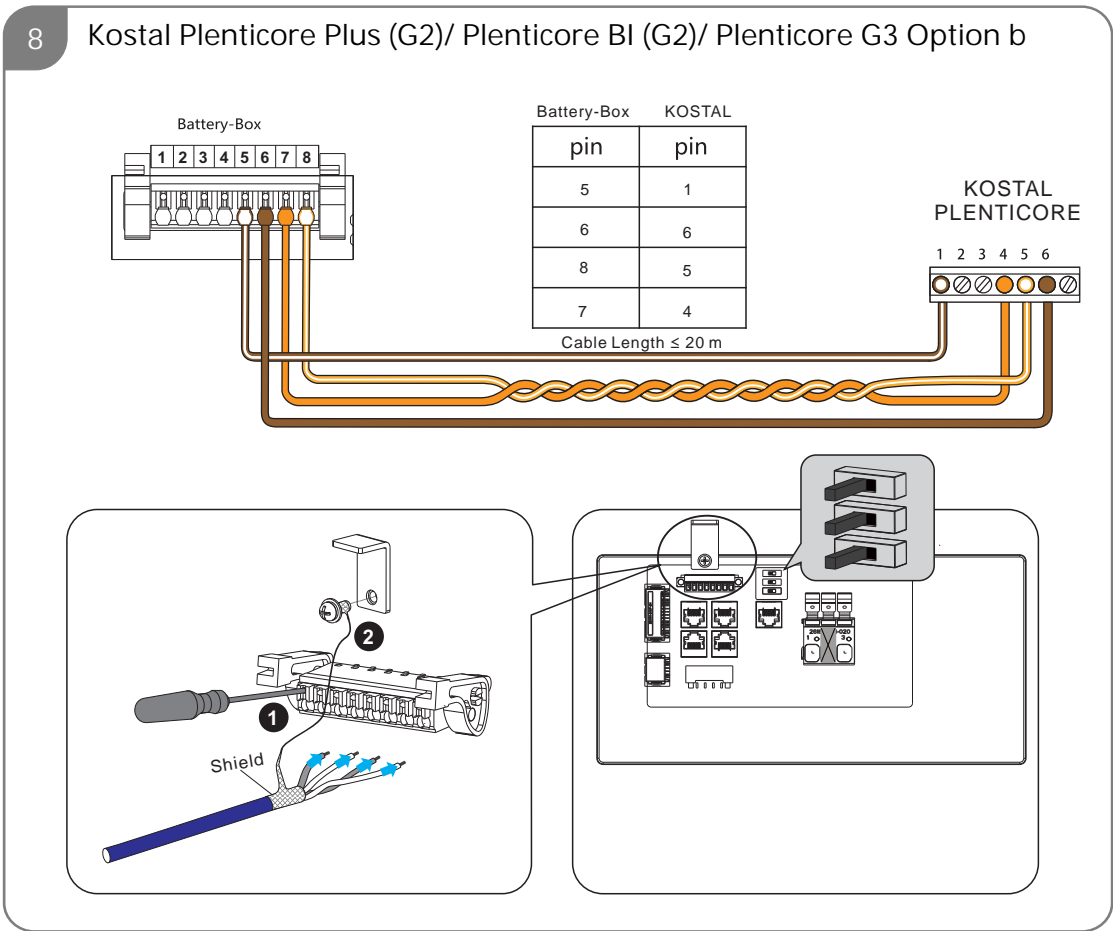
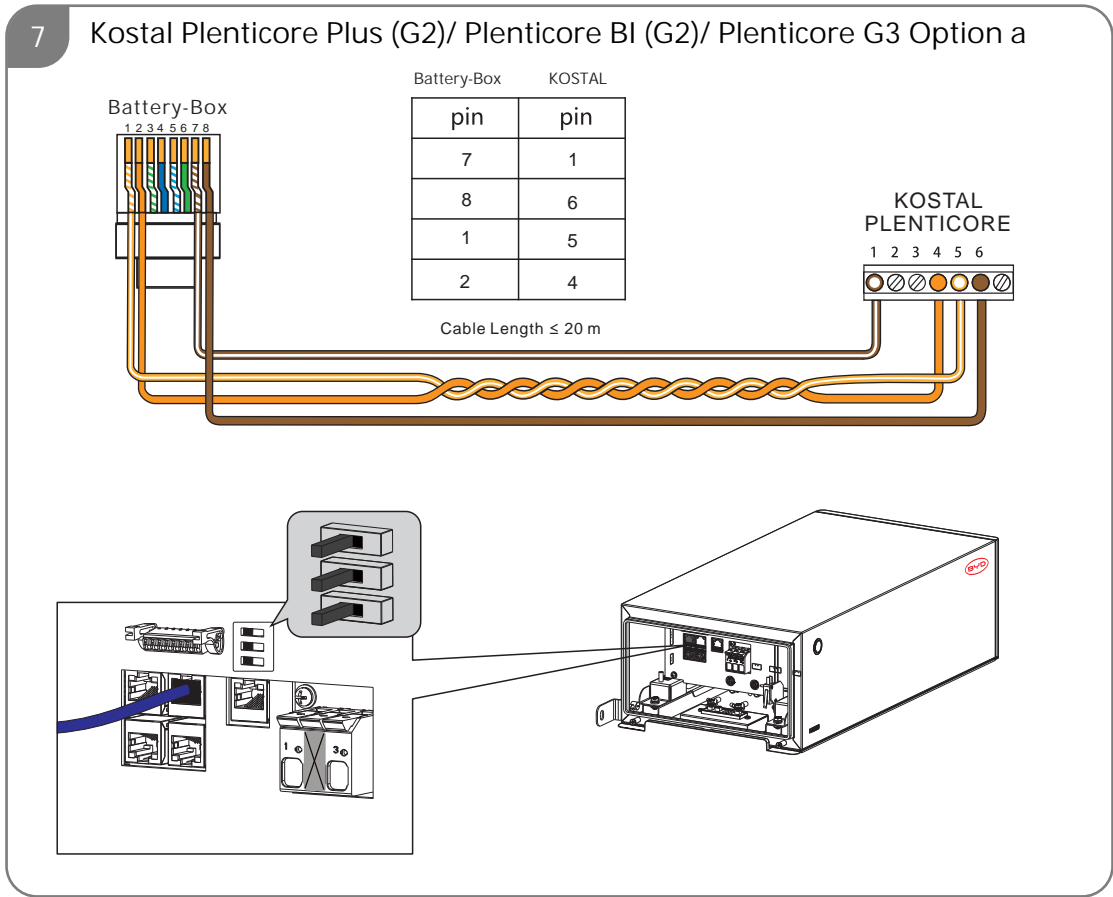

9

Kostal Piko MP Plus

Battery-Box

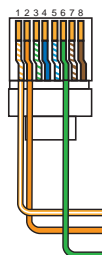

Battery-Box KOSTAL

| pin | pin |
|-----|-----|
| 1 | 3 |
| 2 | 4 |
| 6 | 2 |

Cable Length ≤ 20 m



RS485 (A)

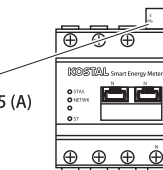

KOSTAL Smart Energy Meter

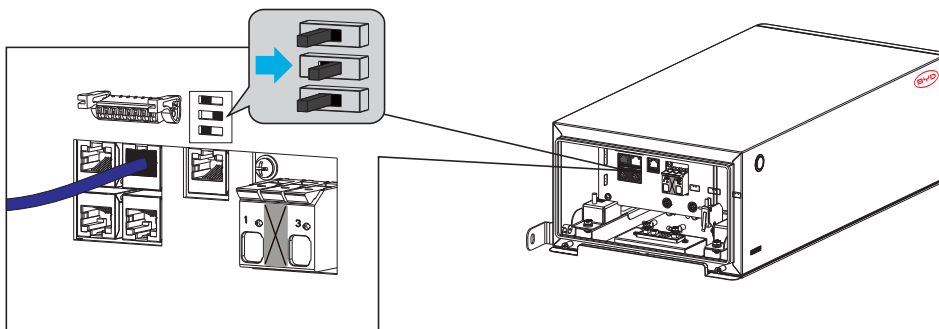

10

Kostal Piko BA

Battery-Box

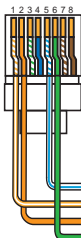

Battery-Box KOSTAL

| pin | pin |
|-----|-----|
| 1 | 5 |
| 2 | 6 |
| 5 | 3 |
| 6 | 4 |

Cable Length ≤ 20 m

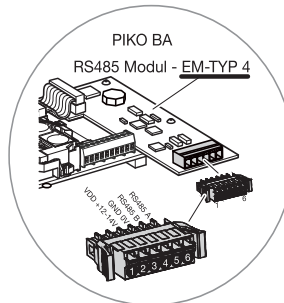
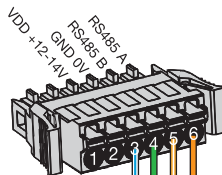

PIKO BA

RS485 Modul - EM-TYP 4

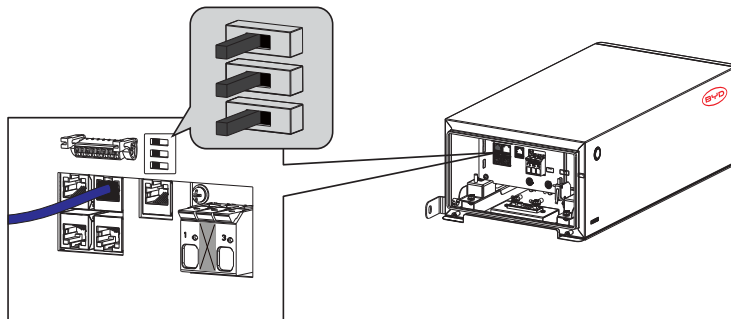

11 Kaco blueplanet hybrid 6.0-10.0 TL3

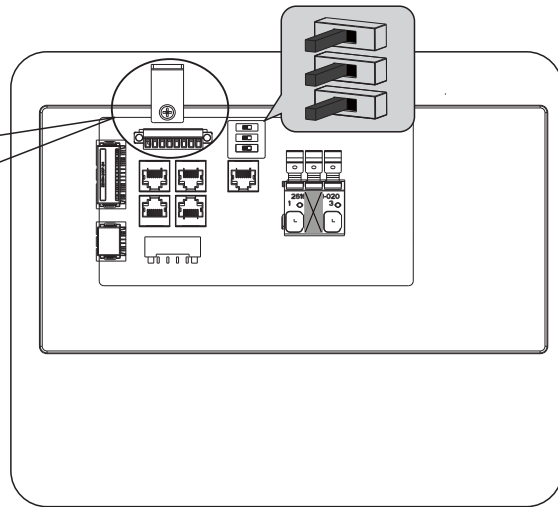
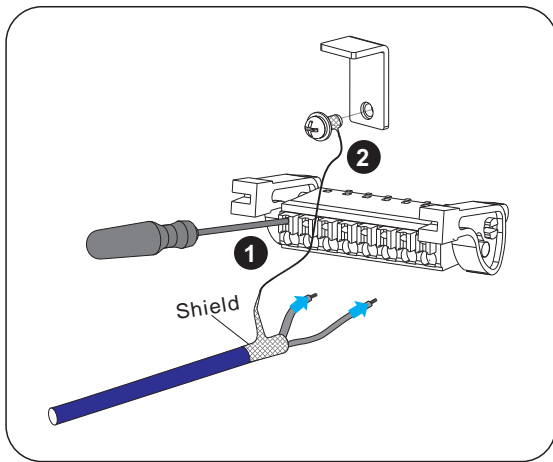
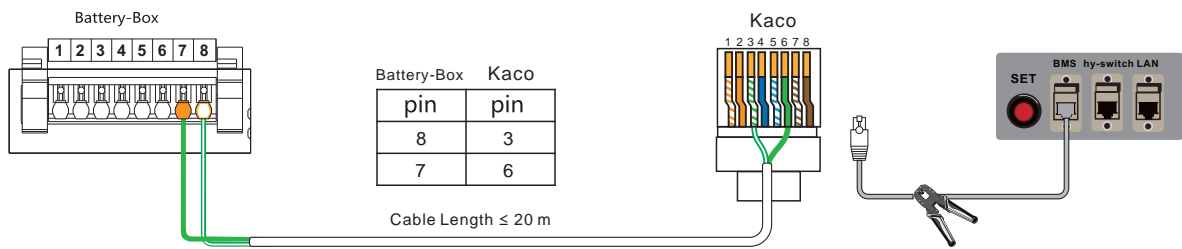

12 Kaco NH Option a

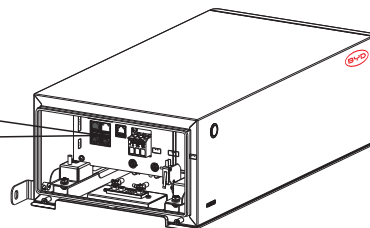
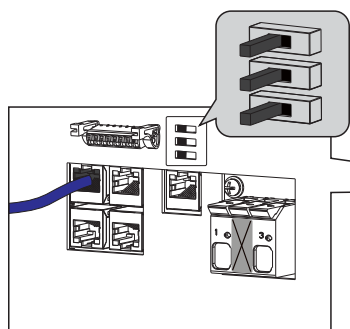
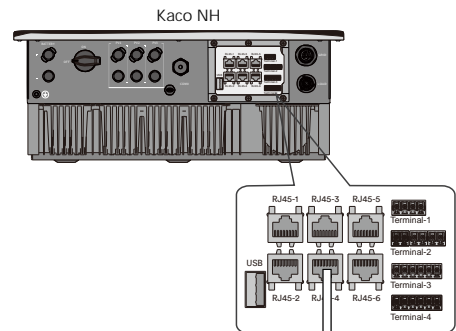
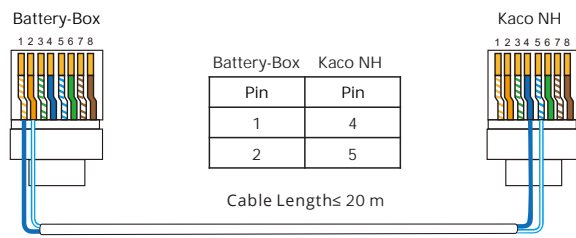

13 Kaco NH option b

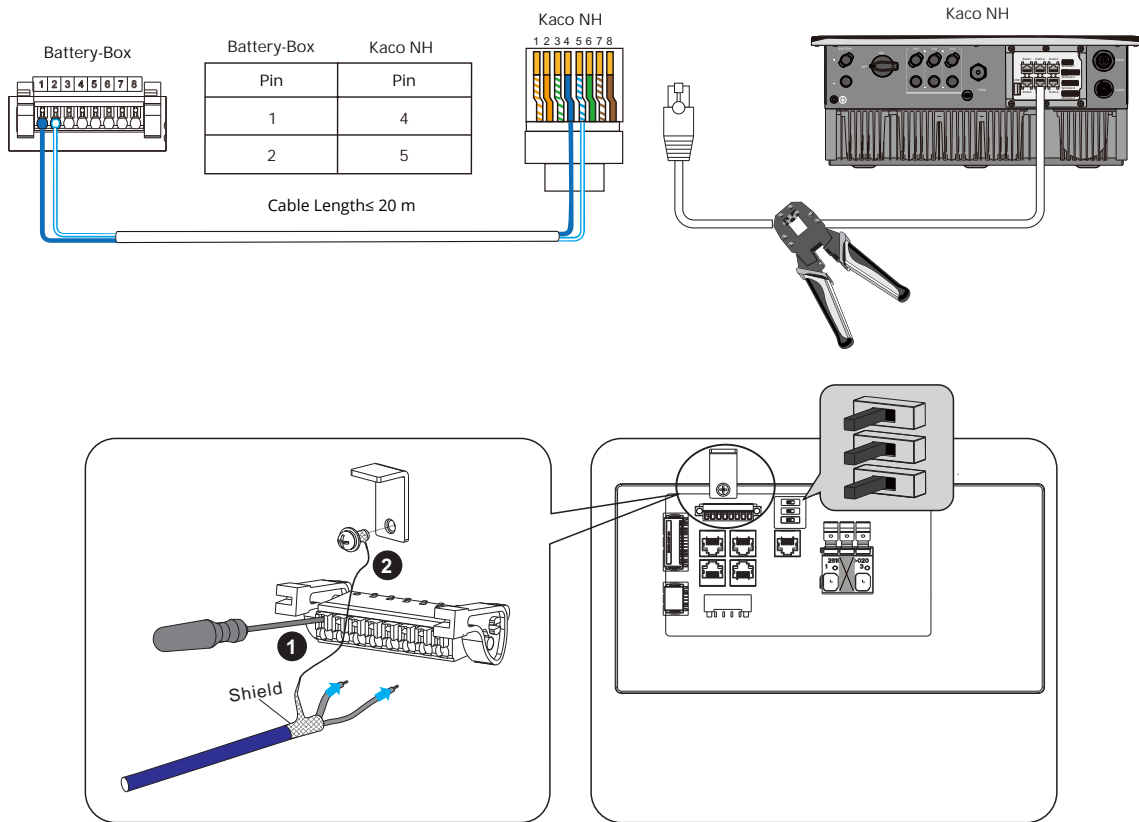

14 SUNGROW SH5.0_6.0_8.0_10RT Option a

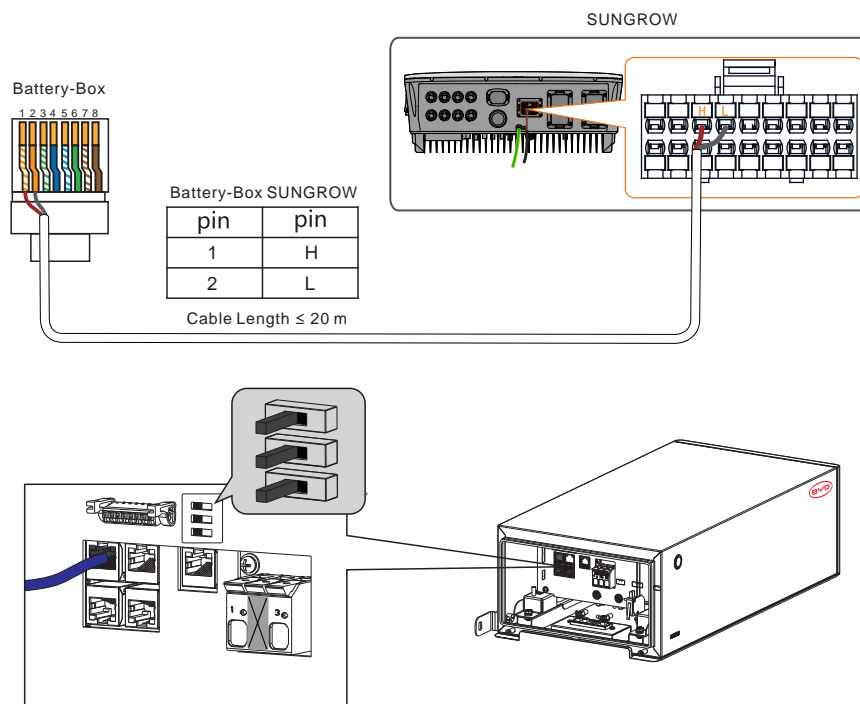

15 SUNGROW SH5.0_6.0_8.0_10RT Option b

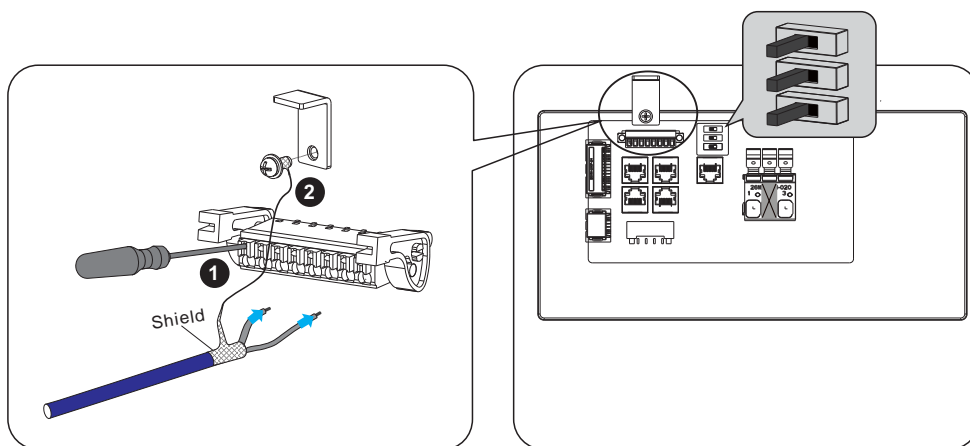
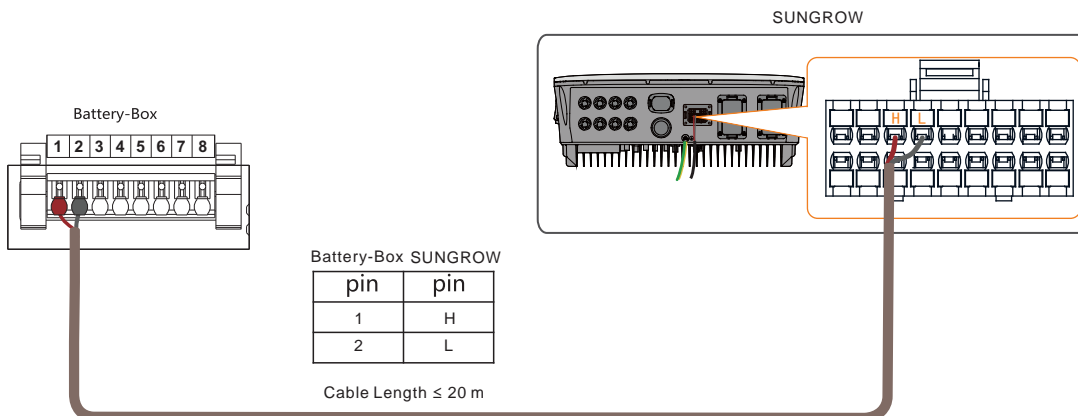

16 SUNGROW SH3.0/ 3.6/ 4.0/ 5.0/ 6.0 RS Option a

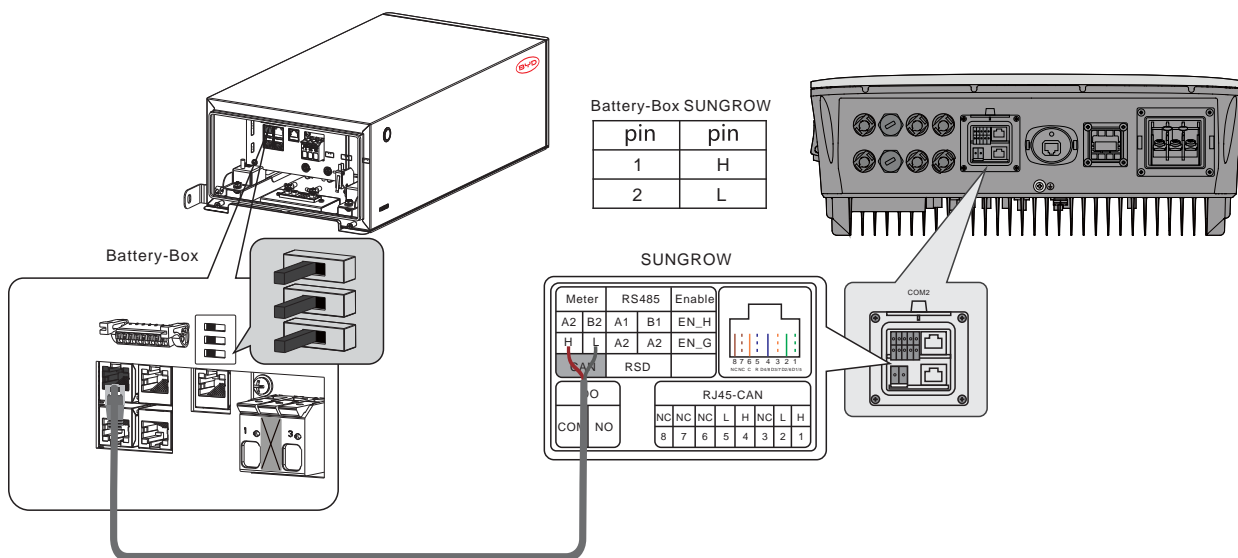

17 SUNGROW SH3.0/ 3.6/ 4.0/ 5.0/ 6.0 RS Option b

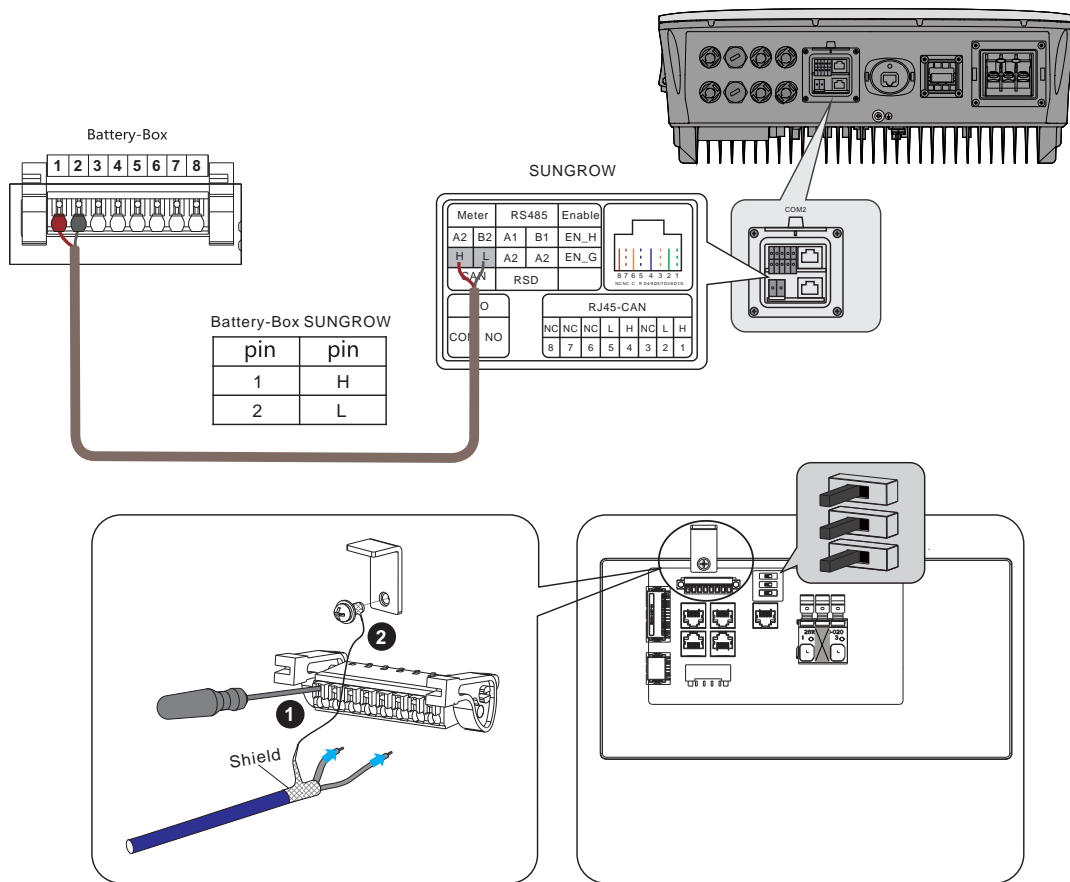

18 Fronius Symo Hybrid Option a

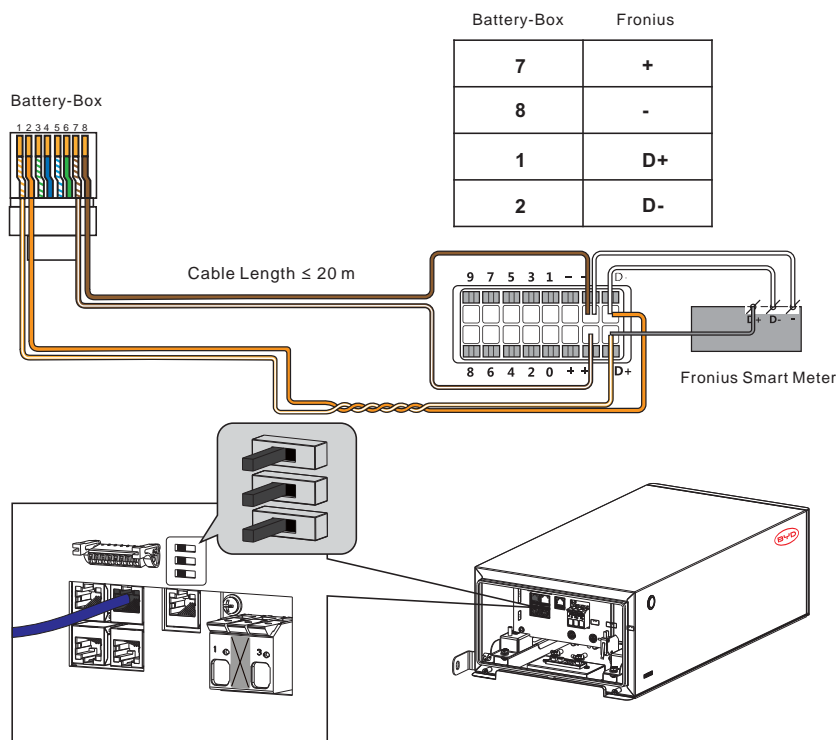

19 Fronius Symo Hybrid Option b

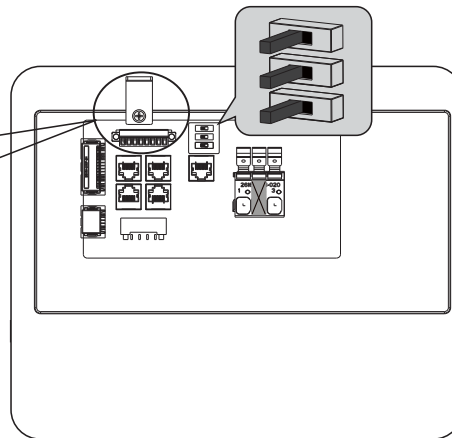
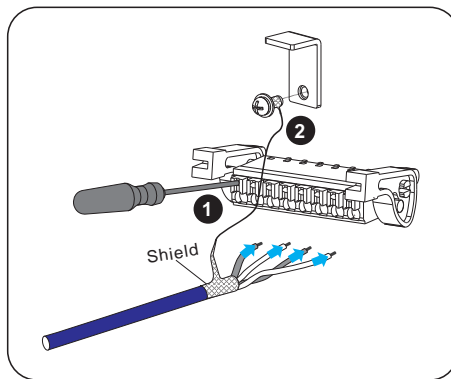
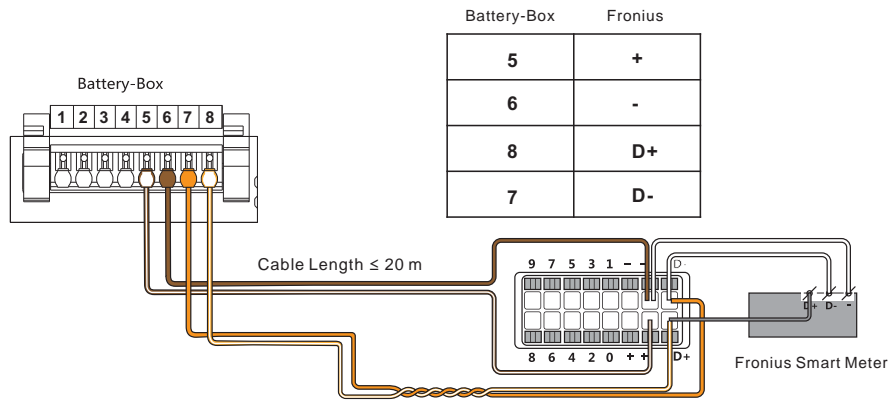

20 Fronius Primo Gen24 Plus/ Symo Gen24 Plus Option a

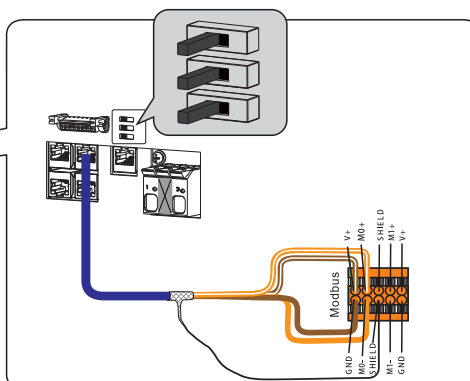
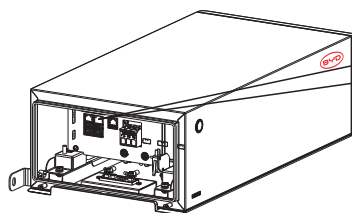
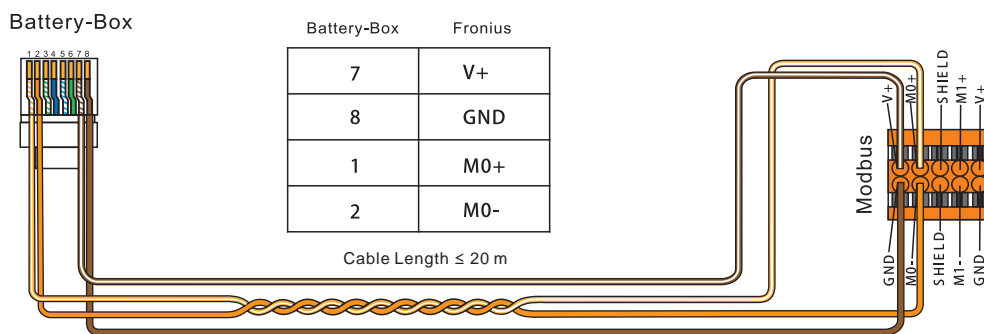

21 Fronius Primo Gen24 Plus/ Symo Gen24 Plus Option b

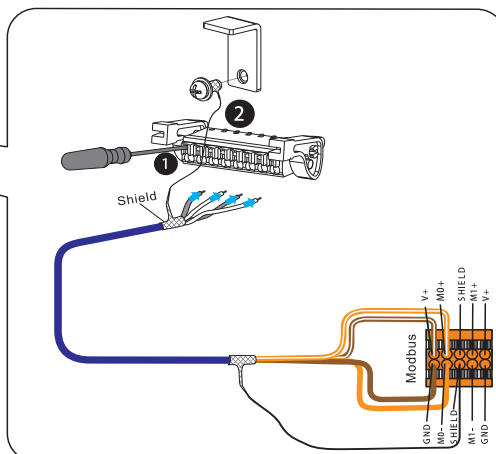
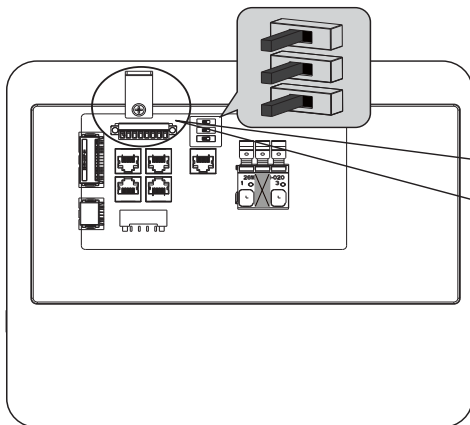
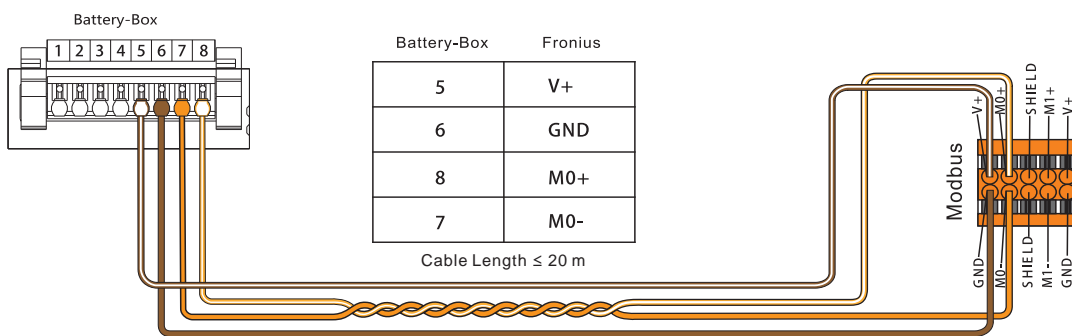

22 Ingeteam Option a

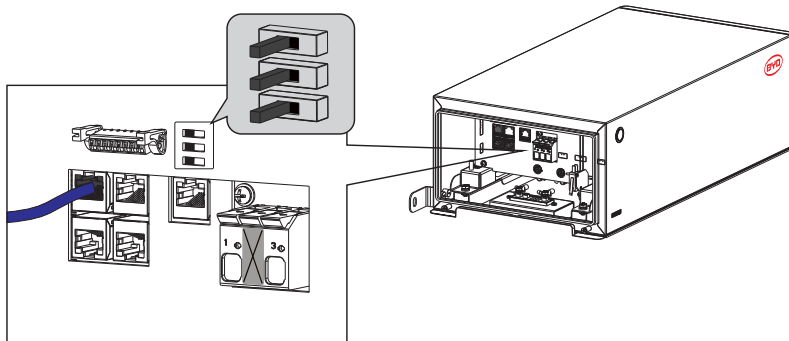
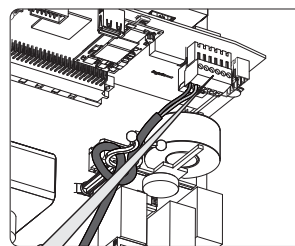
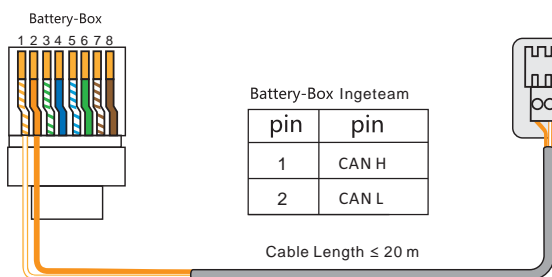

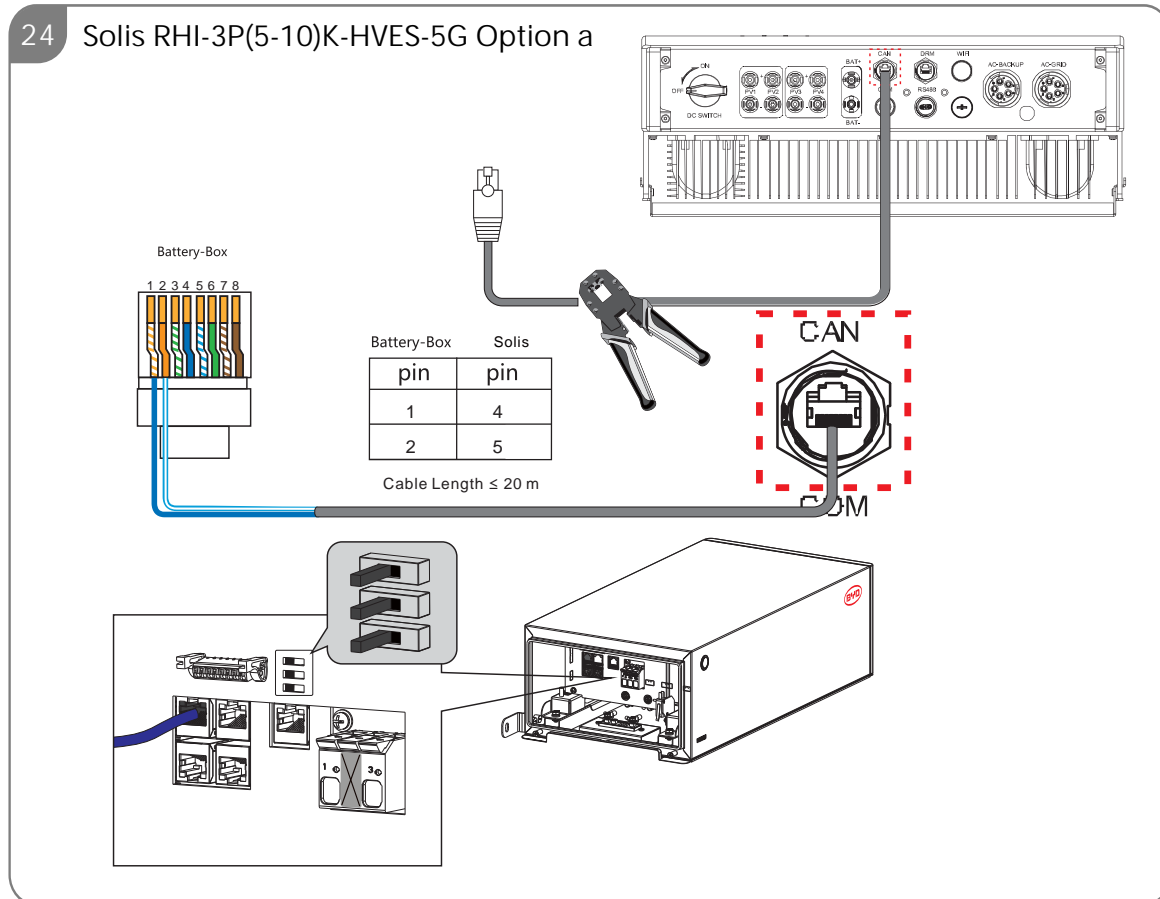
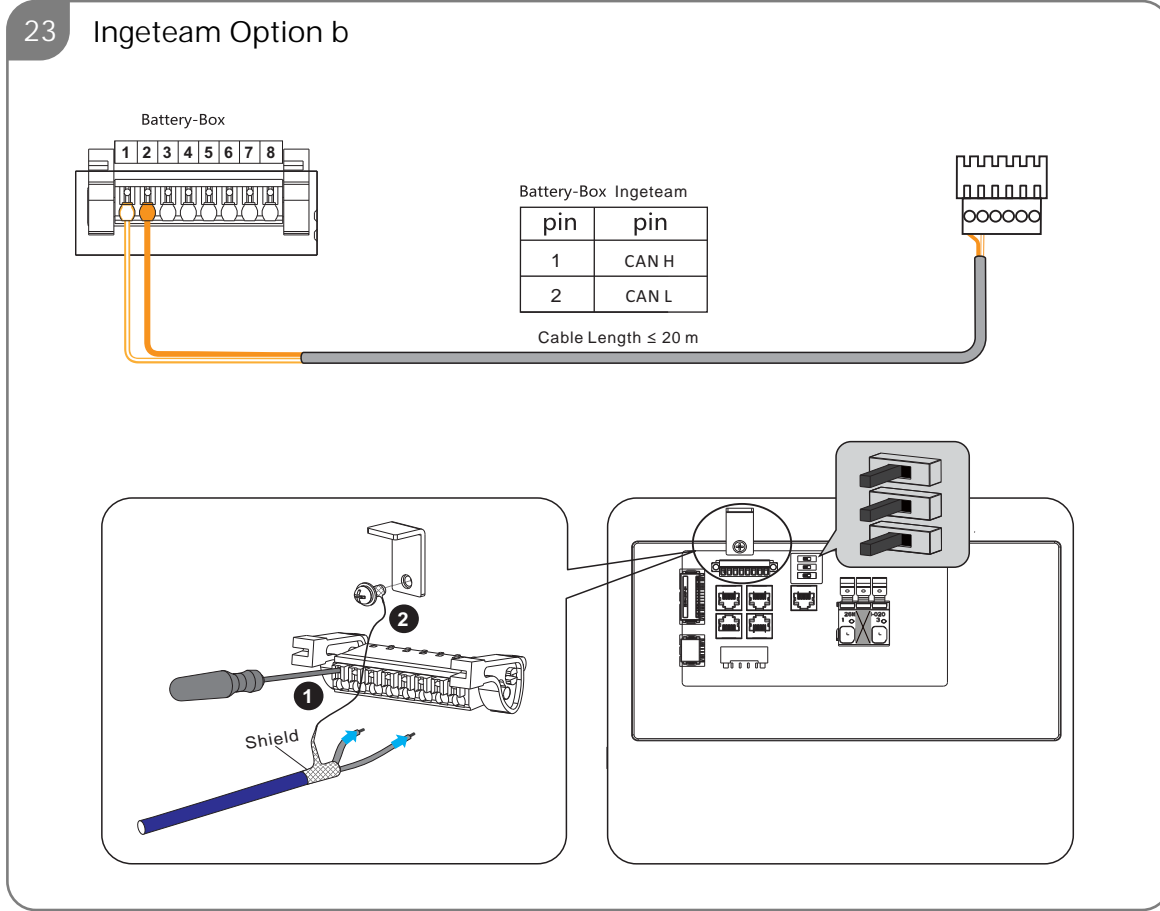

25 Solis RHI-3P(5-10)K-HVES-5G Option b

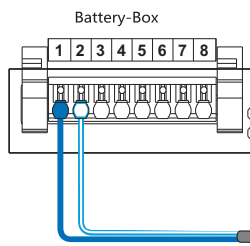

| Battery-Box pin | Solis pin |
|-----------------|-----------|
| 1 | 4 |
| 2 | 5 |

Cable Length ≤ 20 m

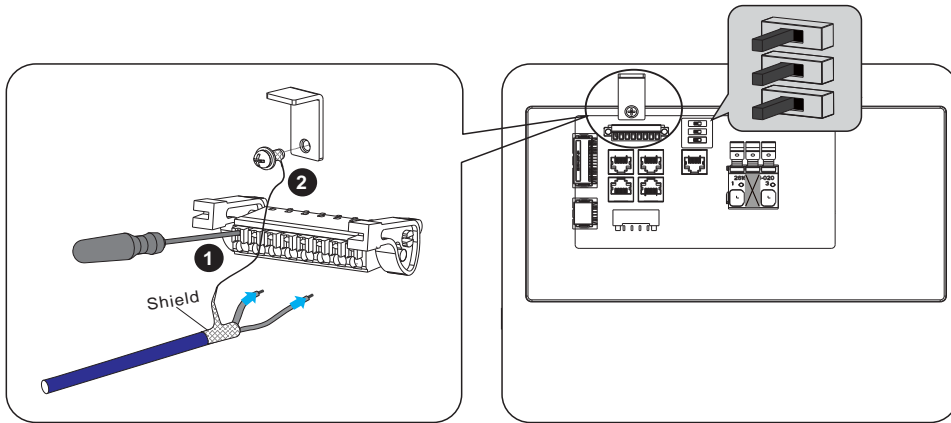
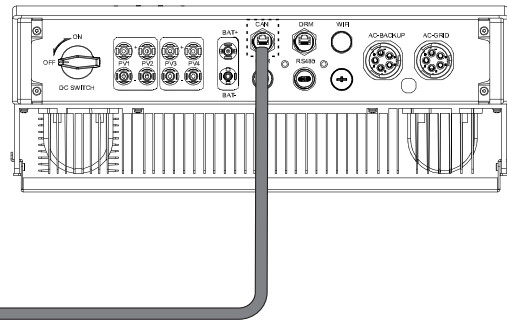

26 Solis S6-EH3P(3-10)K-H-EU/ S6-EH3P(3-10)K2-H Option a

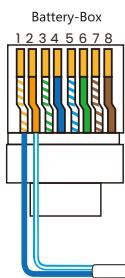

| Battery-Box pin | Solis pin |
|-----------------|-----------|
| 1 | 4 |
| 2 | 5 |

Cable Length ≤ 20 m

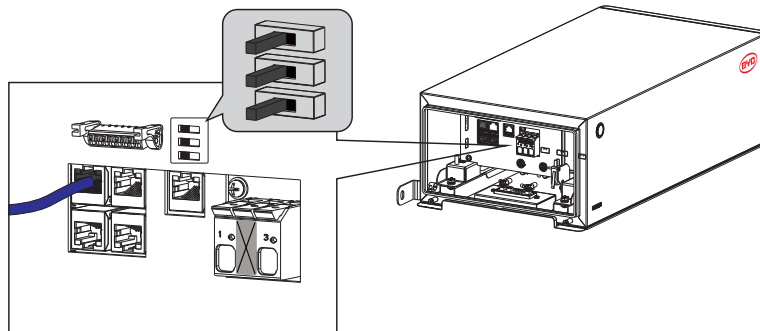
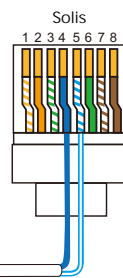

27 Solis S6-EH3P(3-10)K-H-EU/ S6-EH3P(3-10)K2-H Option b

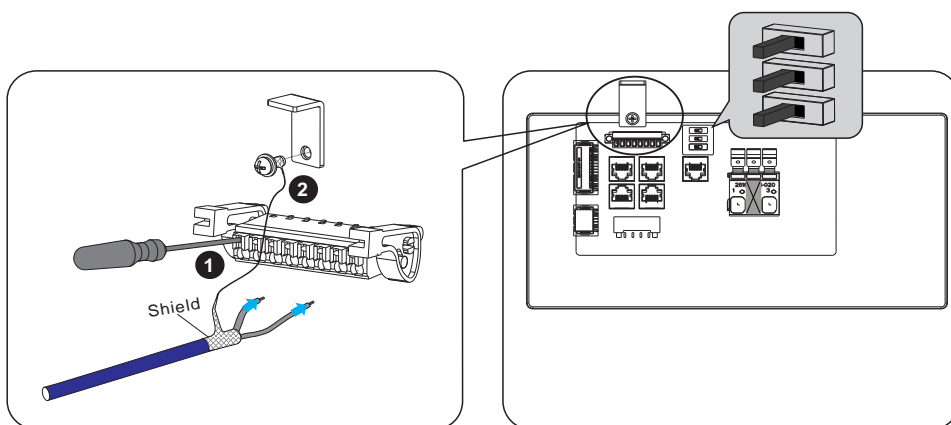
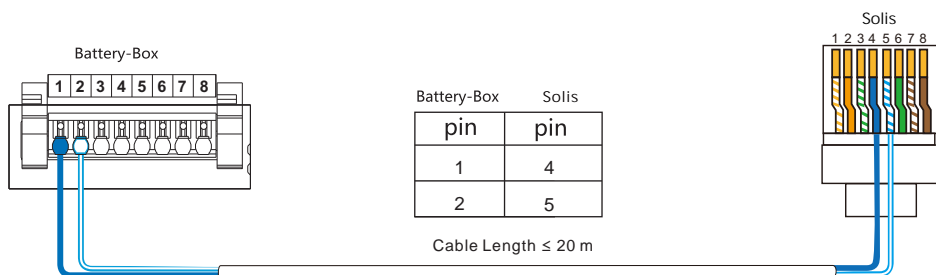

28 Deye SUN-(5-20)K-SG01HP3-EU-AM2 Option a

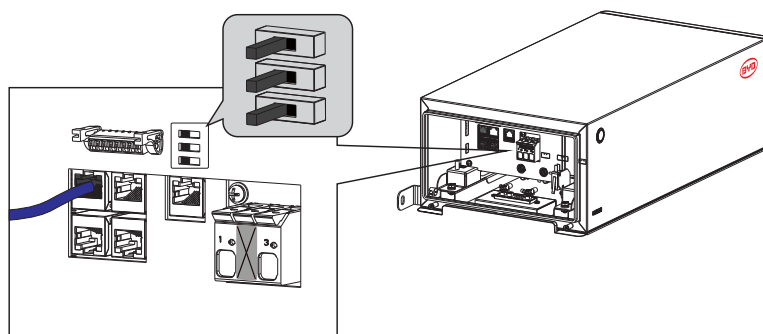
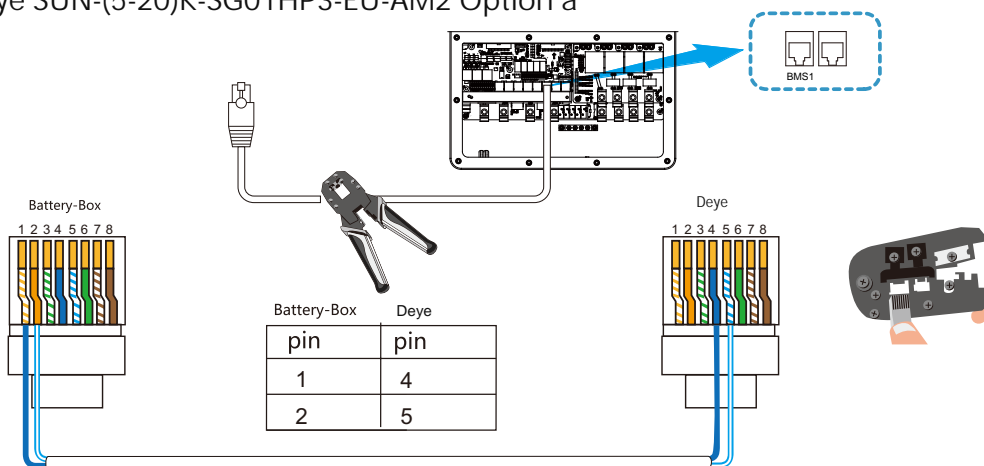

29 Deye SUN-(5-20)K-SG01HP3-EU-AM2 Option b

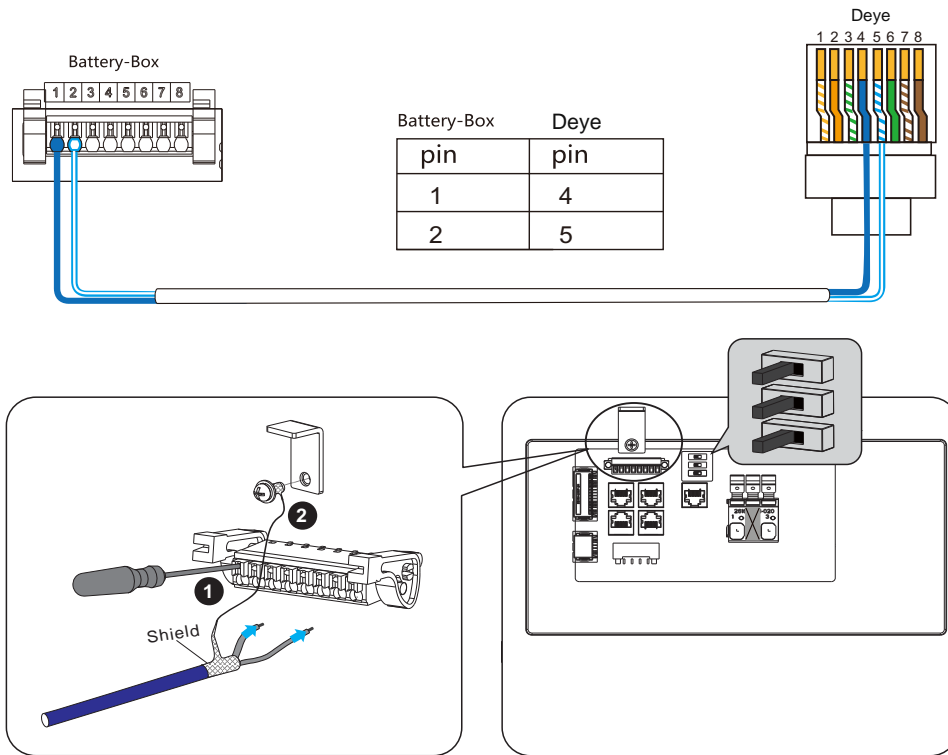

30 Deye SUN-50K-SG01HP3-EU-BM4 Option a

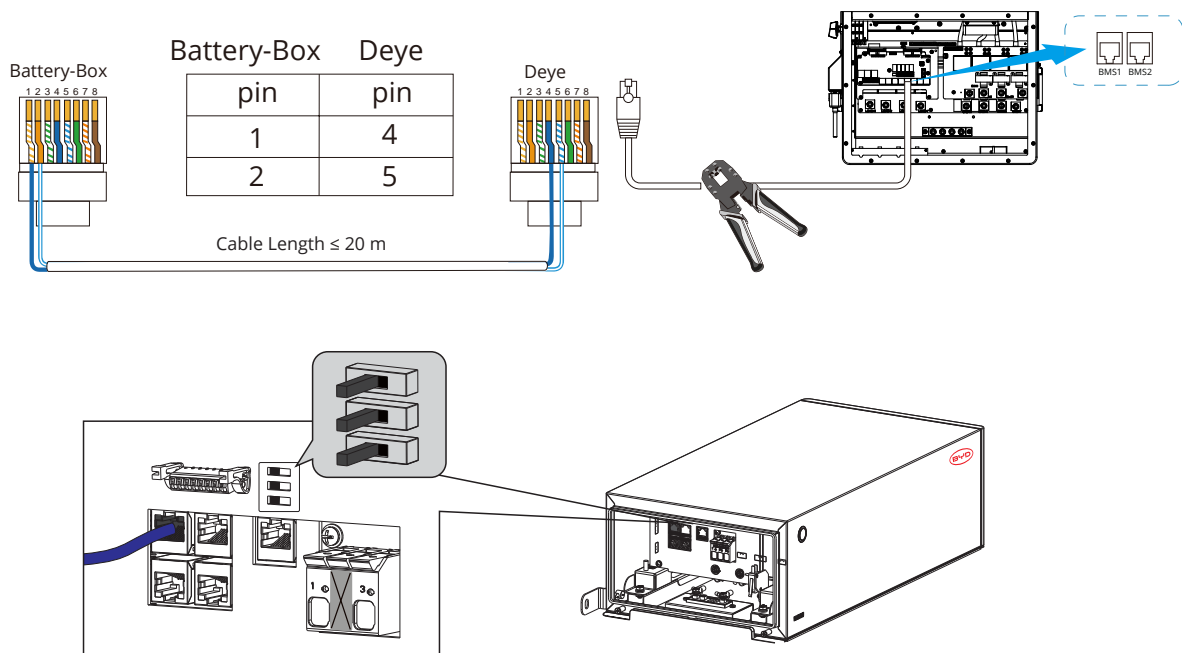

31 Deye SUN-50K-SG01HP3-EU-BM4 Option b

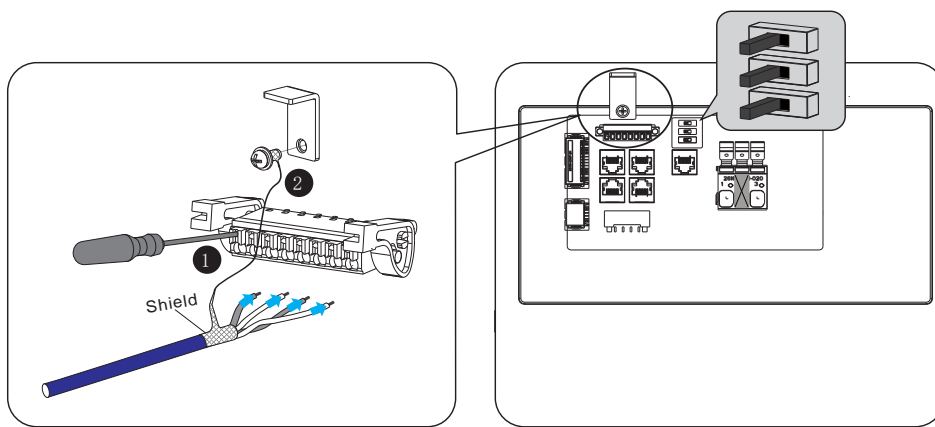
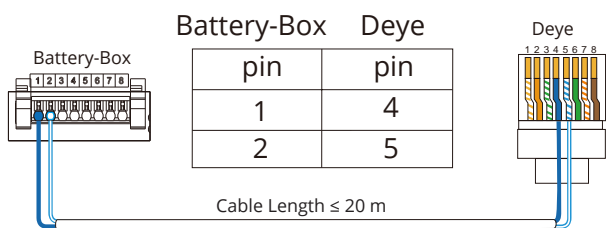

32 GE GEH 5.0/ 8.6/ 10-1U-10 Option a

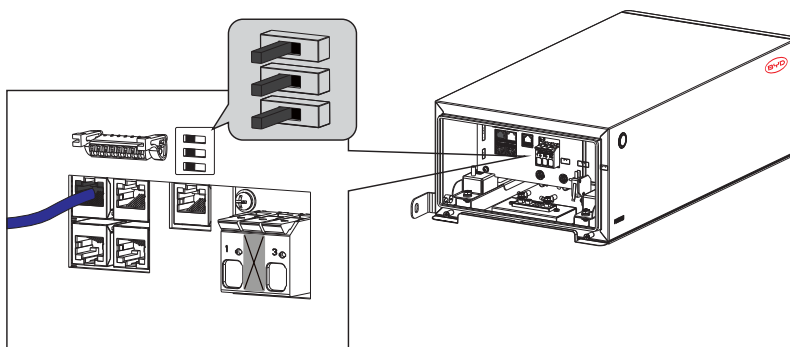
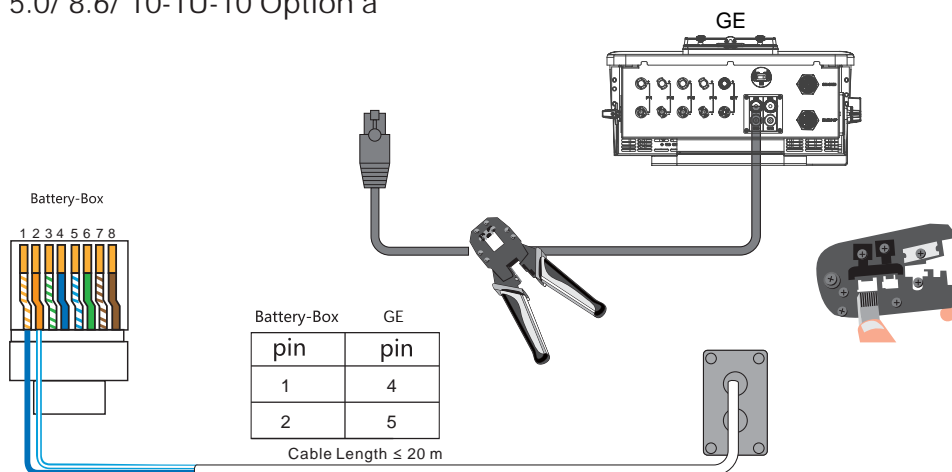

33 GE GEH 5.0/ 8.6/ 10-1U-10 Option b

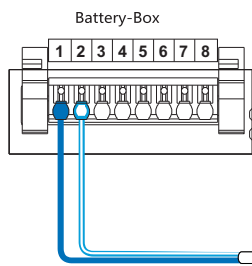

| Battery-Box pin | GE pin |
|-----------------|--------|
| 1 | 4 |
| 2 | 5 |

Cable Length ≤ 20 m

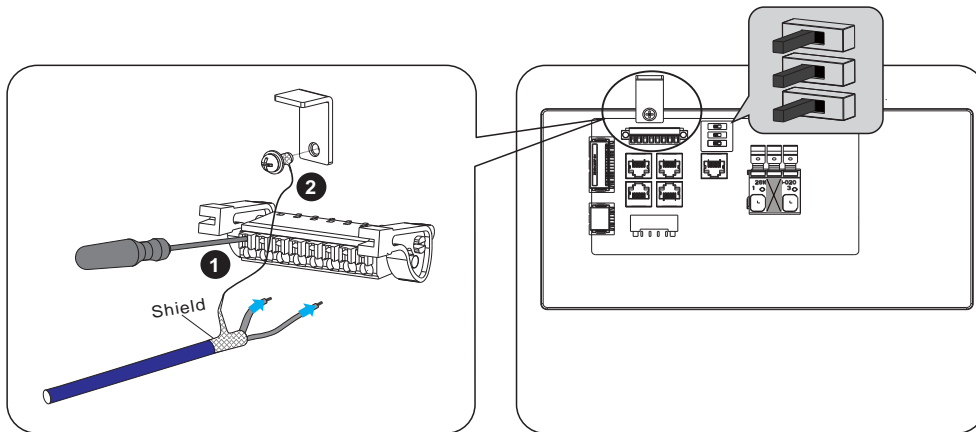
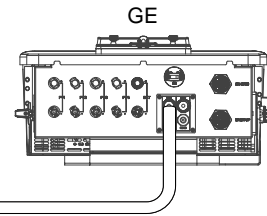

34 Solplanet Option a



| Battery-Box Pin | Solplanet Pin |
|-----------------|---------------|
| 1 | 4 |
| 2 | 5 |

Cable Lengths ≤ 20 m

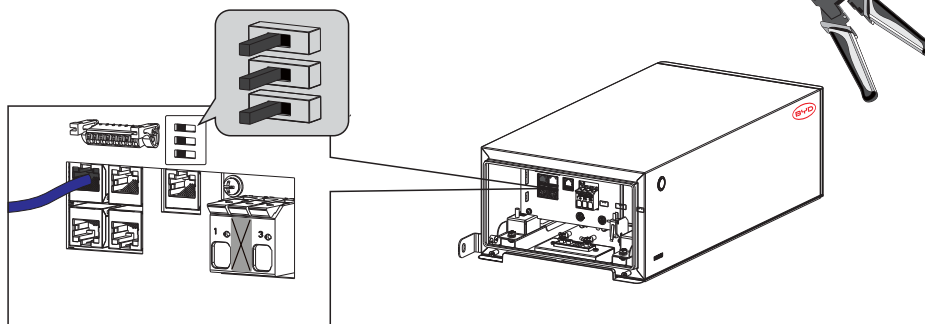
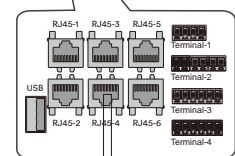
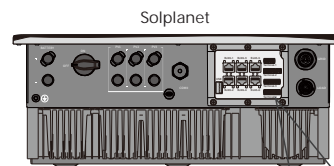

35 Solplanet option b

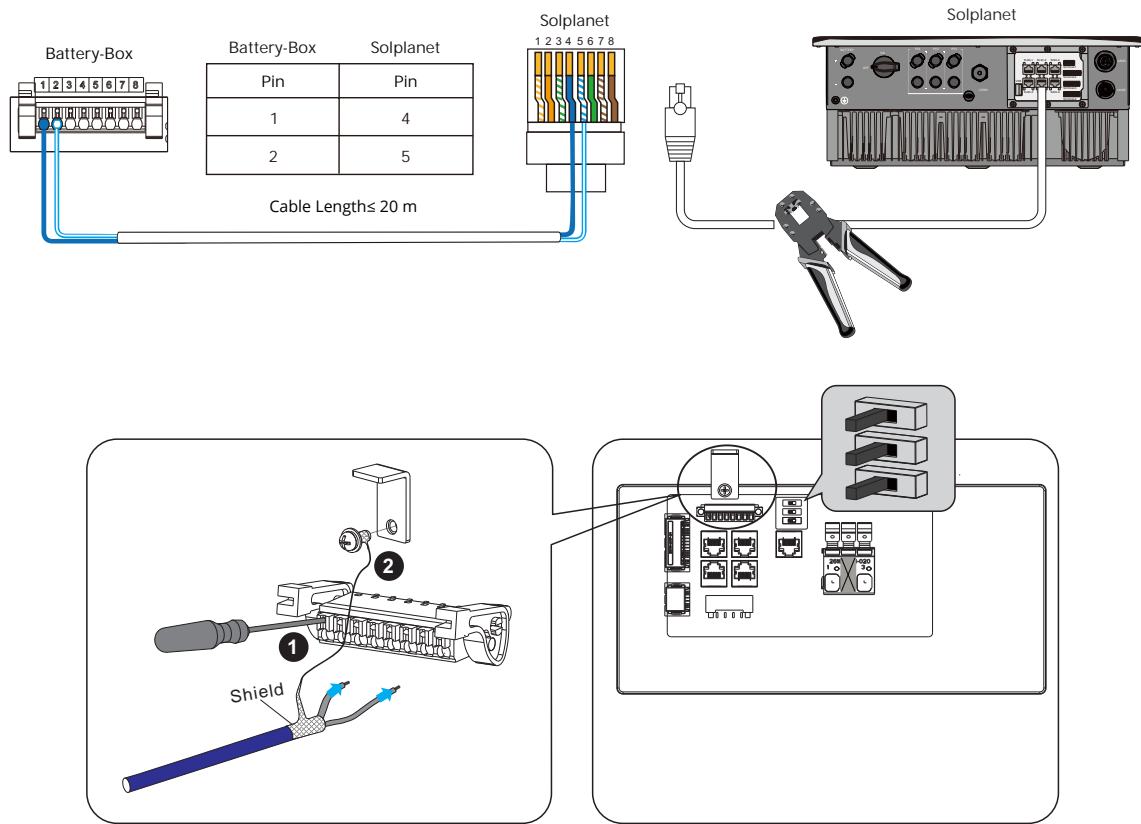

36 Western CO HHS 3000-6000/ HBS 3000-6000 Option a

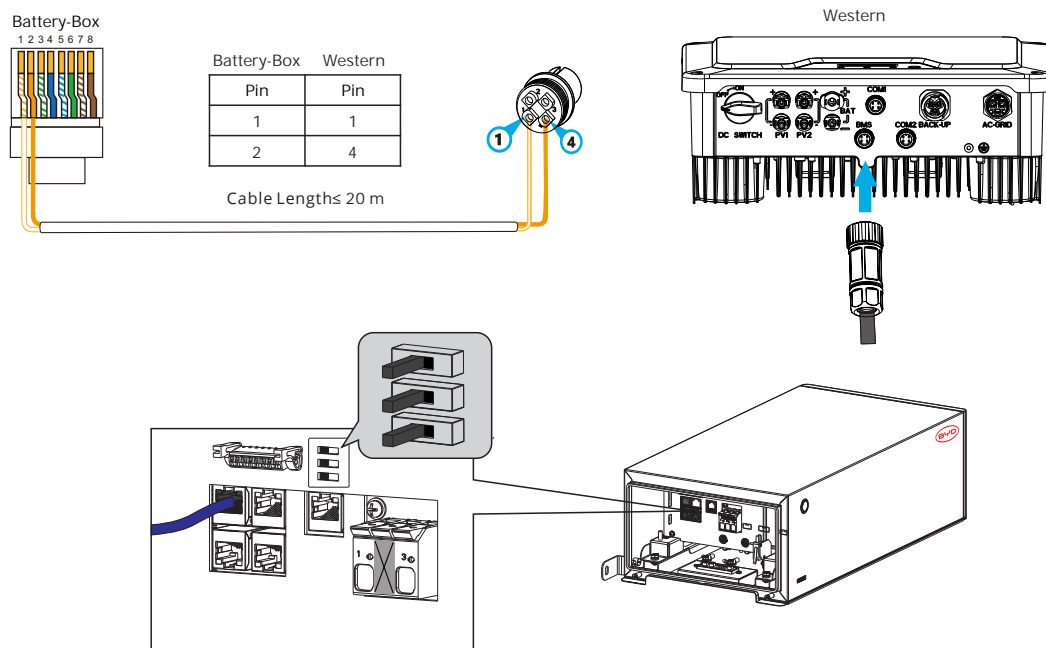

37 Western CO HHS 3000-6000/ HBS 3000-6000 Option b

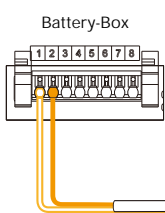

| Battery-Box | Western |
|-------------|---------|
| Pin 1 | Pin 1 |
| Pin 2 | Pin 4 |

Cable Lengths ≤ 20 m

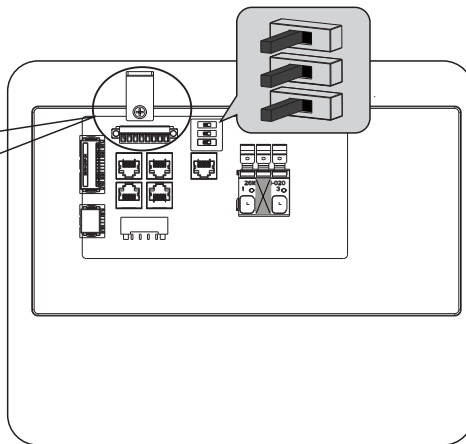
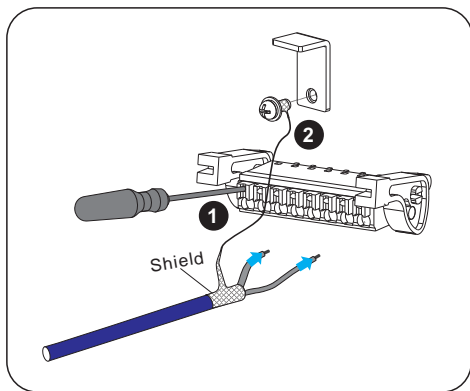
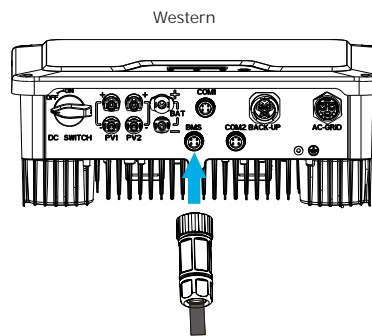
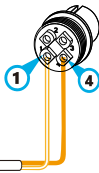

38 Western CO HHT 5000-12000/ HBT 5000-12000 Option a

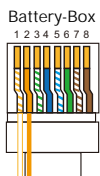

| Battery-Box | Western |
|-------------|---------|
| Pin 1 | Pin 14 |
| Pin 2 | Pin 15 |

Cable Lengths ≤ 20 m

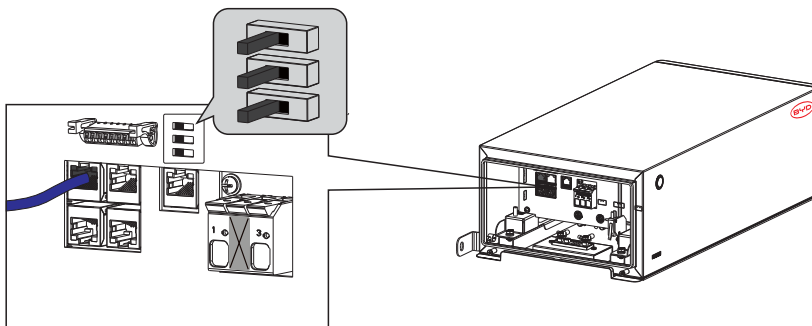
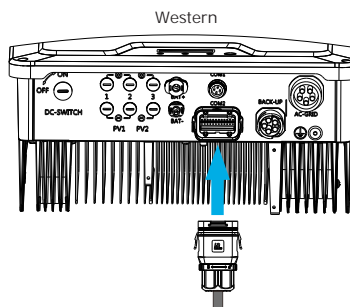
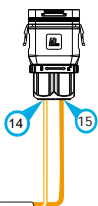

39 Western CO HHT 5000-12000/ HBT 5000-12000 Option b

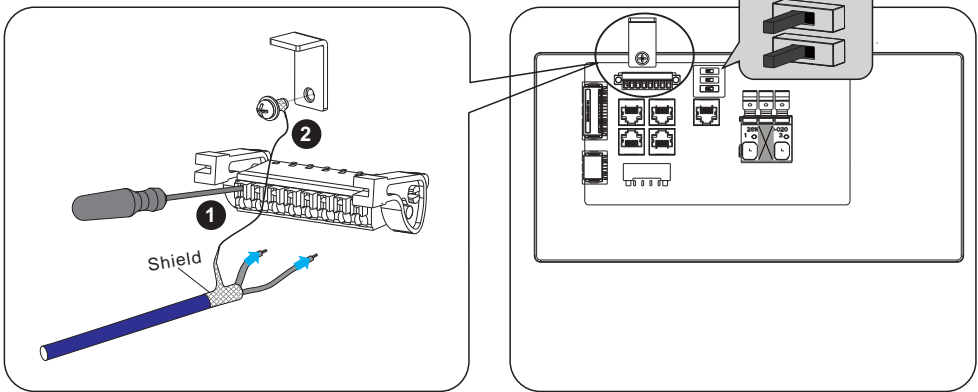
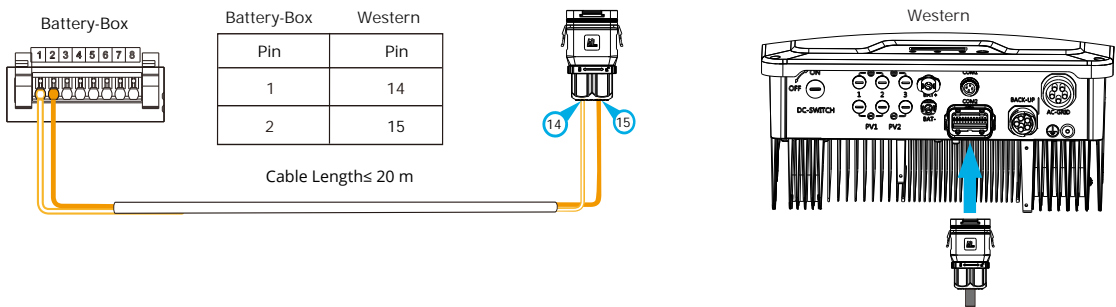

40 Sosen SSE-HH3K-6K-P1-EU Option a

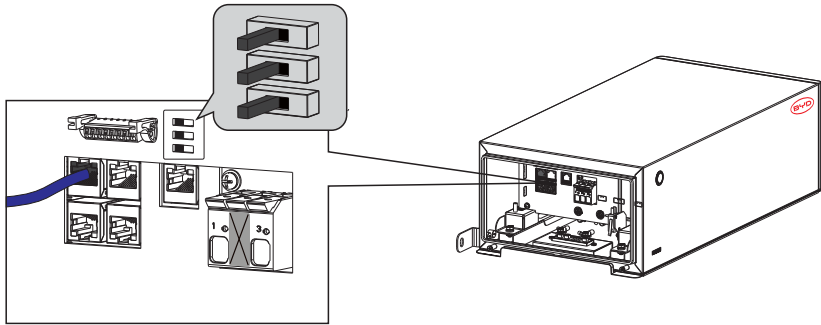
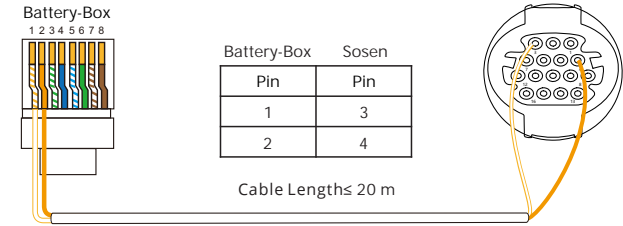

41 Sosen SSE-HH3K-6K-P1-EU option b

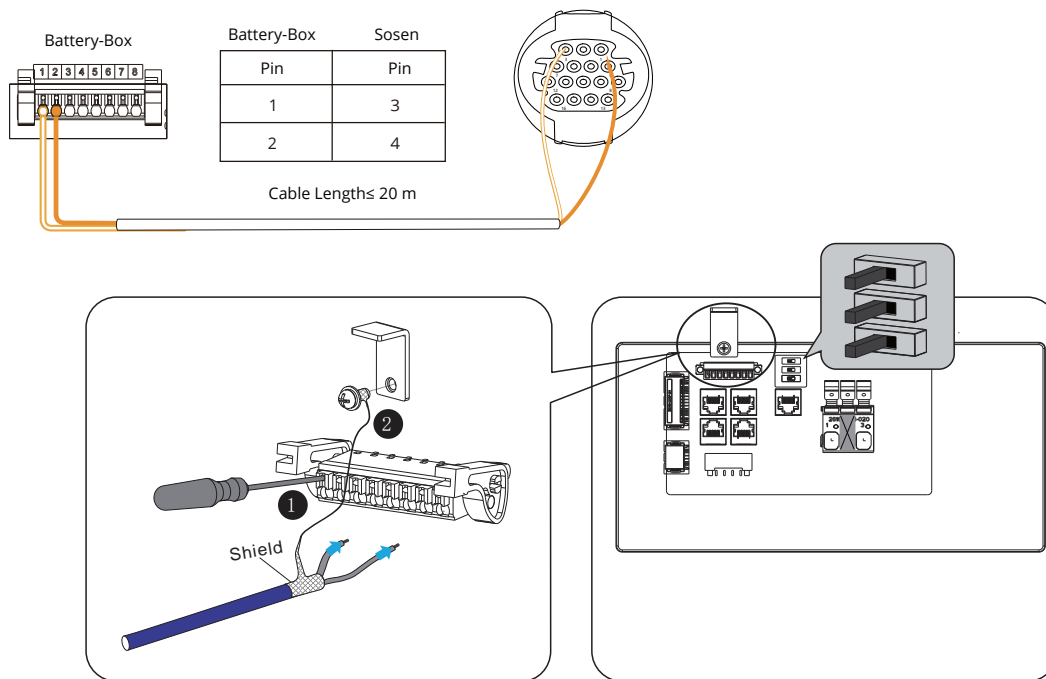

42 GoodWe/ Viessmann/ Canadian Solar Option a

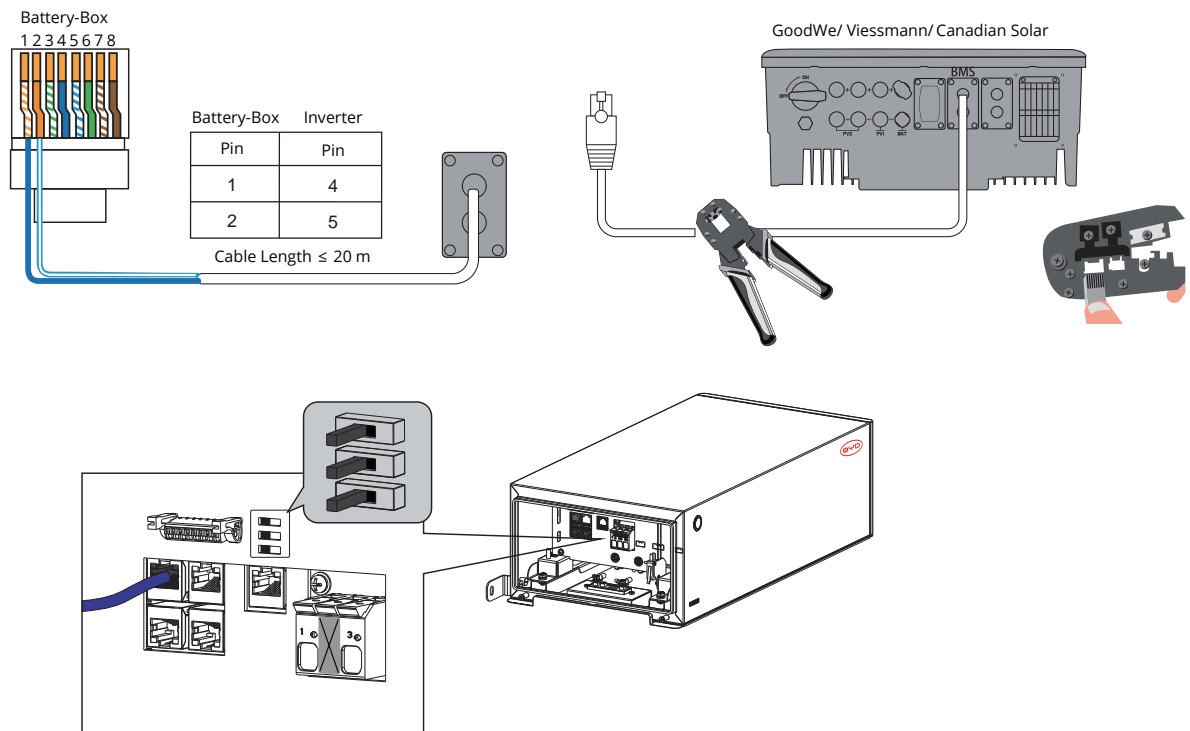

43 GoodWe/ Viessmann/ Canadian Solar Option b

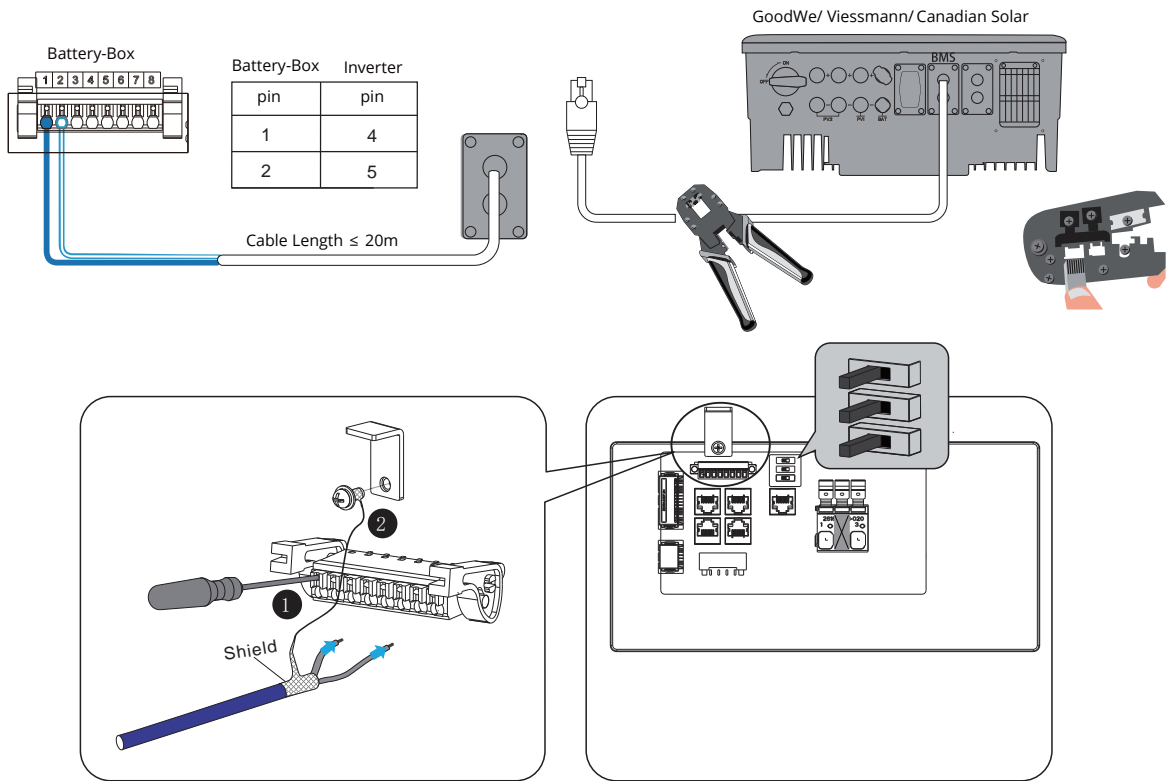

44 Hoymiles Option a

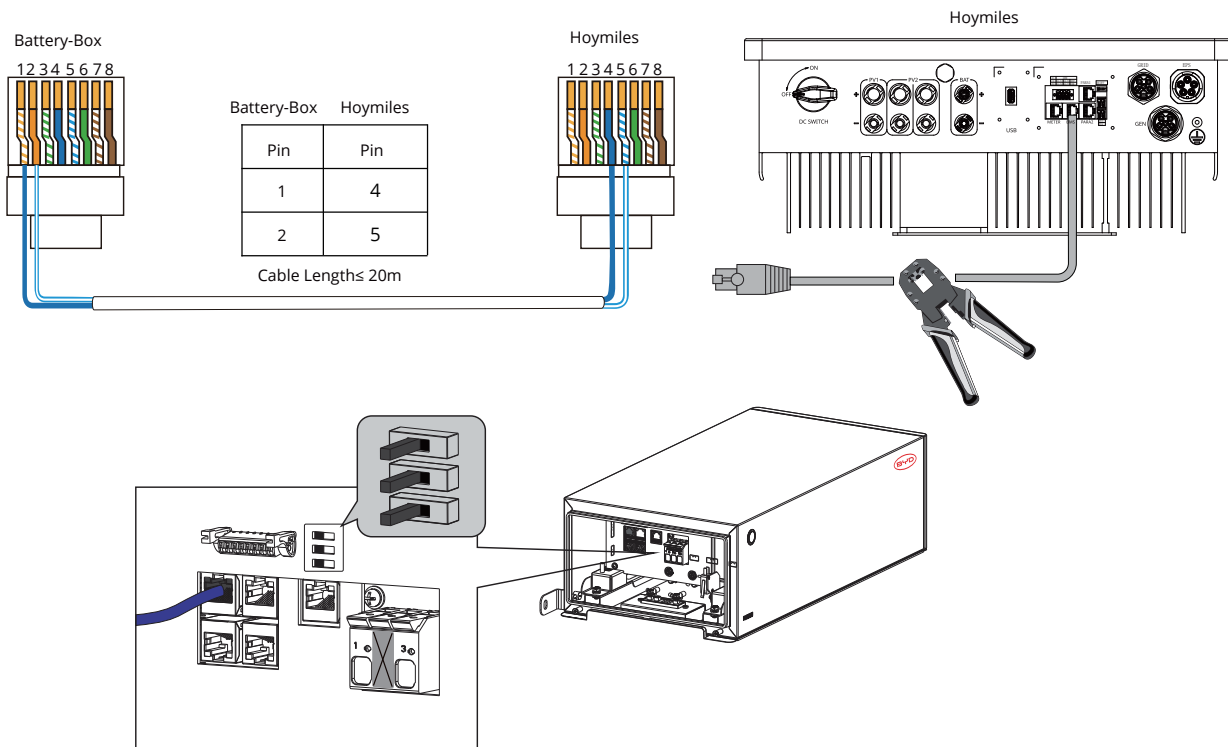

47 Afore AF(3-20)K-TH Option b

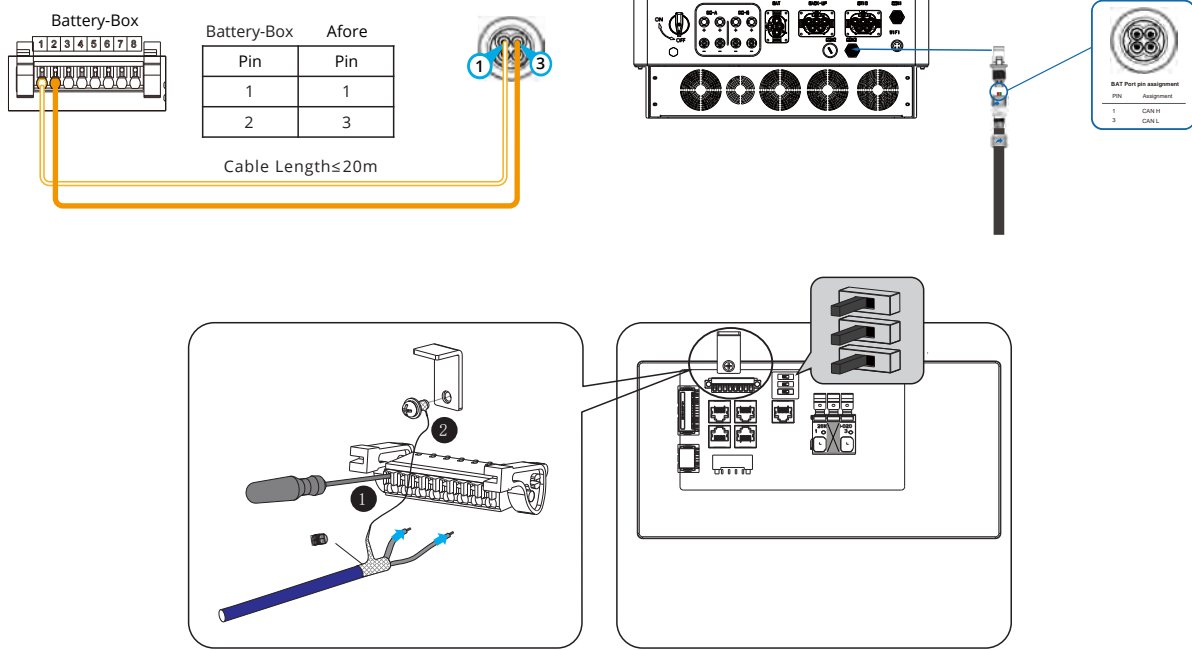

48 Maxhub PHN(5-10)KT-BH2 Option a

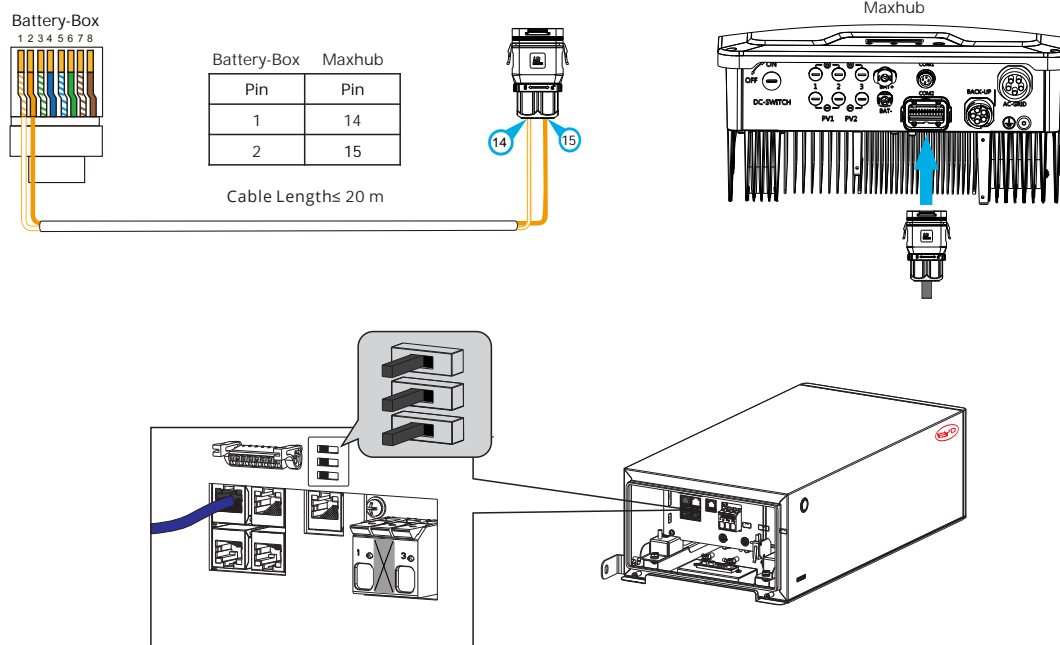

49 Maxhub PHN(5-10)KT-BH2 Option b

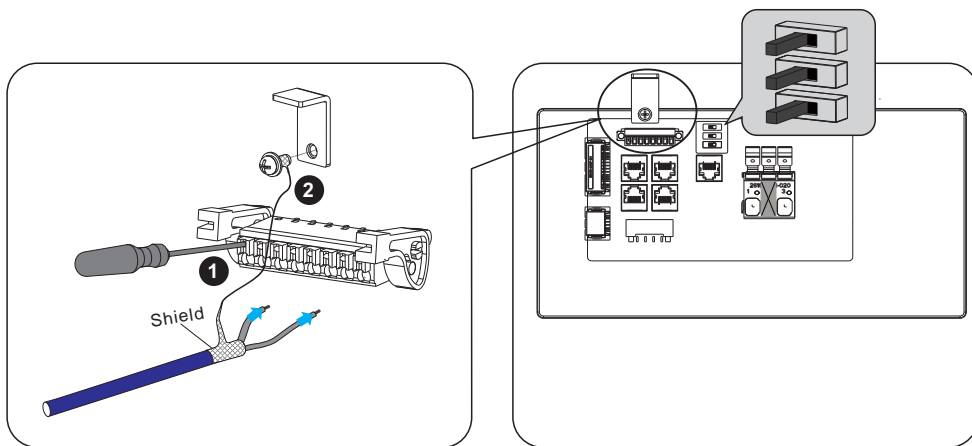
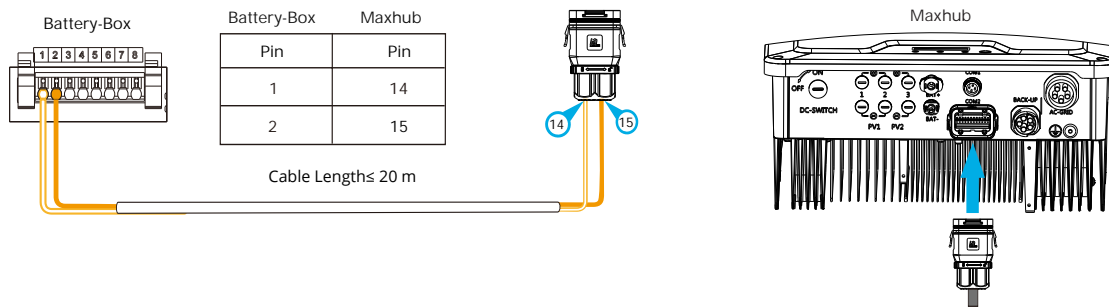

50 Kontron Solar SolBrid 10-3-2/10-3-4 Option a

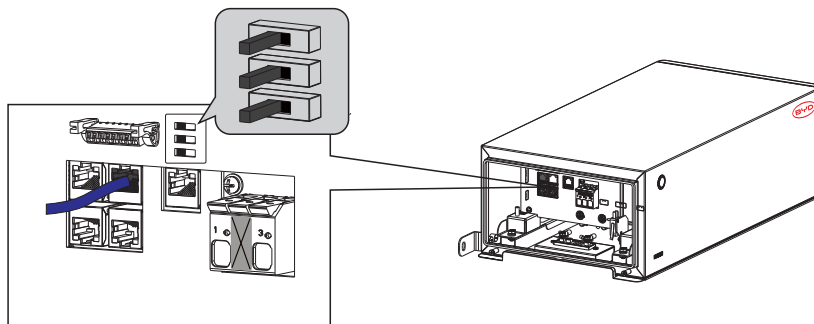
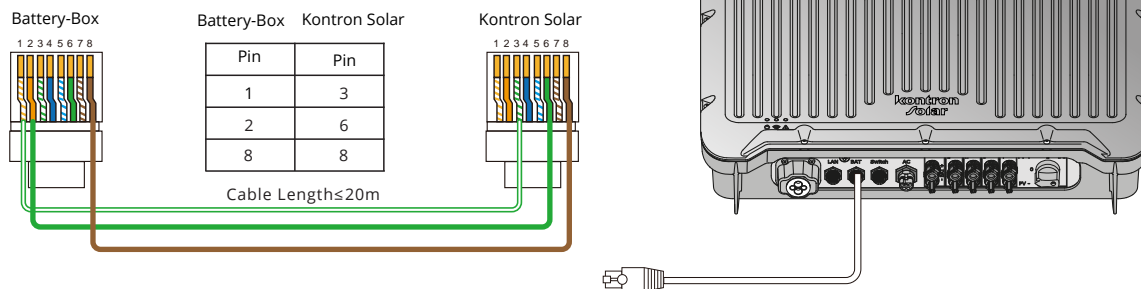

51 Kontron Solar SolBrid 10-3-2/10-3-4 Option b

